

Public Hearing: YES  NO

Department: Planning & Sustainability

**SUBJECT:**

**COMMISSION DISTRICT(S): COMMISSION DISTRICT 03 SUPER DISTRICT 07**

**Application of Stix & Stones Homes for a major modification of zoning conditions #1 and #2 pursuant to Z-22-1245596 to increase the number of units and construct a single-family detached cottage development at 1484 & 1520 Columbia Drive.**

**PETITION NO: D3-2023-1142 CZ-23-1246630**

**PROPOSED USE: Single-family, detached cottage development.**

**LOCATION: 1484 & 1520 Columbia Drive, Decatur, Georgia 30032**

**PARCEL NO. : 15-186-04-028; 15-186-04-029**

**INFO. CONTACT: Adam Chappell, Planner**

**PHONE NUMBER: 404-371-2155**

**PURPOSE:**

Application of Stix & Stones Homes for a major modification of zoning conditions #1 and #2 pursuant to Z-22-1245596 to increase the number of units and construct a single-family detached cottage development within the R-60 (Residential Small Lot) zoning district.

**RECOMMENDATION:**

**COMMUNITY COUNCIL: (Feb. 13, 2024) Approval with conditions. (Oct. 4, 2024) Denial.**

**PLANNING COMMISSION: (March 5, 2024) Full Cycle Deferral. (Nov. 2, 2023) Two-Cycle Deferral.**

**PLANNING STAFF: (March 5, 2024) Approval with conditions. (Nov. 2, 2023) Two-Cycle Deferral.**

**STAFF ANALYSIS:** The subject properties were rezoned from the R-75 (Residential Medium Lot-75) Zoning District to the R-60 (Residential Small Lot-60) zoning district on July 26, 2022 (Z-22-1245596). This rezoning was approved with conditions that restricted the development site to no more than 11 single-family detached dwellings (see enclosed conditions, site plan, and other approved documents). The applicant proposes a major modification to modify Conditions #1 and #2 to allow for up to 16 single-family, fee-simple, cottage dwellings at a density of approximately 5.9 units per acre. The proposed cottage development is a permitted principal use in the R-60 Zoning District, subject to design regulations in Section 5.7.9. of the *Zoning Ordinance*, which was added as a text amendment by the Board of Commissioners on December 12, 2023. The original site plan with the proposal, dated August 24, 2023 and titled "*Columbia Cottages*", showed clusters of cottage dwellings centered around several courtyards which qualify as areas of enhanced open space typical of cottage developments. This site plan, however, contained numerous zoning deficiencies including a lack of streetscaping, lot compatibility, and compliance with cottage development standards that were in place at the time. Significant deficiencies with proposed stormwater detention facilities were noted by Land Development, Roads and Drainage, and Watershed. As a result, at its meeting on November 16, 2023, the Board of Commissioners granted this case a *two-cycle deferral* to give the applicant sufficient time to redesign their proposal. A revised site plan dated January 17, 2024 showed an updated design that addressed a majority of concerns raised by Planning Staff with the initial submittal. On February 15, 2024, a roundtable discussion was held with the applicant and other County departments; many of the previous deficiencies were deemed to be adequately addressed with the new proposal including underground stormwater detention. However, some concerns regarding the location of certain units and the distance from proposed off-street parking were raised by the Planning Commission at their meeting

held on March 5, 2024. A third plan was submitted in response to these concerns on March 8, 2024. This plan relocates several of the proposed cottage units to be closer to Columbia Drive and reorients the overall development to be centered on a central common area that is perpendicular to the aforementioned right-of-way. The units and parking areas are located so that no unit is more than 200 feet from an off-street parking space, as required per Section 5.7.9. (F) of the *Zoning Ordinance*. From a land use and density perspective, the proposed single-family cottages appear to be consistent with the following strategies and policies of the Suburban Character Area policy of the *DeKalb County 2050 Unified Plan*: “Permit cottage court developments, accessory housing units, new well-designed, small-scale infill multi-family residences and other innovative housing types to increase housing choice, income diversity, and limited neighborhood density” (pg. 39). An increase in density may be appropriate on this property, which fronts a minor arterial road between commercial nodes located approximately 1,800 feet to the north (Columbia Drive/Belvedere Lane) and approximately 1,900 feet to the south (Columbia Drive/Peachcrest Road). Furthermore, an appropriately designed cottage subdivision with maximum building heights of one-and-a-half stories and unit sizes not exceeding 1,200 square feet would not be expected to adversely affect the existing character of uses in the general vicinity, which are primarily single-family dwellings of similar height and size. Therefore, upon review of Section 7.3.5., the Department of Planning and Sustainability recommends “Approval with the attached recommended conditions”.

**PLANNING COMMISSION VOTE: (March 5, 2024) Full-Cycle Deferral 8-0-0.** Deanna Murphy moved, Jon West seconded for a full cycle deferral to the May 2024 zoning agenda to allow the applicant time to submit a design modification and assign parking spaces. **(November 2, 2023) Two-Cycle Deferral 8-0-0.** Vivian Moore moved, Edward Patton seconded for a 2-cycle deferral to the March 2024 zoning agenda, per Staff recommendation.

**COMMUNITY COUNCIL VOTE/RECOMMENDATION: (Feb. 13, 2024) Approval with conditions 7-3-0** that 1) the Applicant revise the plan to provide for the maximum parking allowed by the cottage ordinance; and, 2) the Applicant to provide such parking conveniently located for each proposed cottage home. **(Oct. 4, 2023) Denial.** Discussion included that smaller cottage lots were not consistent with character and lot sizes of surrounding residential neighborhoods and potential lack of parking.

**CZ-23-1246630 (2023-1142)**  
**Staff Recommended Conditions 03/15/2024**  
**Major Modification of Conditions Pursuant to Z-22-1245596**  
**1484 and 1520 Columbia Drive**  
**Decatur, GA 30032**

- 1) ~~The development shall have a maximum of eleven (11), detached, single-family homes. General compliance with the site plan received May 3, 2022, shall be required. The community must establish a homeowners' or property owners' association (HOA or POA) per the Zoning Ordinance and Land Development Code. The HOA/POA shall limit the number of rental units to 10% of the total homes constructed.~~ The development site shall be improved with no more than sixteen (16) fee-simple single-family detached cottages. Unit sizes shall not exceed 1,200 square feet of heated floor area. The proposed alignment of dwellings and other improvements shall conform with all standards of Section 5.7.9. of the *Zoning Ordinance*. Proposed cottages shall be located and centered around a common area of enhanced open space in general conformance to that shown on the site plan dated 03/08/2024, and titled "Columbia Cottages". The site plan is conceptual, however, and the location of the dwelling units may be altered to better support other required improvements, such as off-street parking, open space, and stormwater detention facilities subject to approval of the Planning Director. All dwelling units shall be within 60 feet walking distance along the shortest safe walking route to the nearest point of the common open space.
- 2) All home designs shall be consistent with the enclosed color rendering(s) ~~entitled "2021-12-20-11-10-43,"~~ dated 10/25/2023, including the following building materials: cementitious hardie plank, vinyl glass windows, shingle ~~roofing~~ or metal roofs over porches, ~~stained cedar plank for post beams and gable crosses, and vinyl garage doors,~~ and must comply with the applicable provisions of ~~Article 5 of the Zoning Ordinance~~ Section 5.7.9. of the *Zoning Ordinance* related to building form and design.
- 3) The developer shall construct at least one stacked stone, monument subdivision sign on the community property along Columbia Drive. Signage shall comply with applicable sections of the *Sign Ordinance*.
- 4) Signs shall be posed inside the community and at the curb cut on Columbia Drive to indicate that the southernmost driveway is one-way only into the property.
- 5) A 10-foot sidewalk/multimodal path shall be provided in County right-of-way along the entirety of the development site's frontage on Columbia Drive. A minimum of 10 feet of landscaping shall be provided in the right-of-way, subject to the requirements of Section 5.4.3. Street trees and street lights shall preferably be provided in a landscape strip between the back of curb and multimodal path. Reductions of these requirements may be granted if there are conflicts with existing utility or overhead power lines, topography, or other site conditions as determined by the Planning Director.

- 6) Independent of the landscaping required in the right-of-way per Section 5.4.3., additional landscaping may be required in the front yard of the development site subject to the discretion of the Planning Director. A three (3) foot tall picket or wrought-iron fence shall be provided in the required front yard adjacent to any dwelling units.
- 7) A minimum ten (10) foot natural or landscaped buffer shall be provided around the perimeter of all property lines not subject to streetscape requirements, with the exception of property lines adjacent to any street, alley, or parking areas, for which a five (5)-foot minimum buffer is required. A six (6) foot high opaque fence shall be required along all interior property lines, with the exception that no such fence shall be provided within the required front yard of the development site – along interior lines within this front yard, trees and shrubs shall be planted to provide a vegetative screen.
- 8) At least two (2) pedestrian paths (measuring five (5) feet in width) shall be provided connecting the main common area to the sidewalk/multimodal path along Columbia Drive. Additional connections may be required, subject to the discretion of the Planning Director.
- 9) A homeowners' association or property owners' association (HOA or POA) shall be created to ensure proper maintenance and funding of shared facilities. All areas/facilities interior to the development site, such as stormwater facilities, detention ponds, open spaces, streets, alleys, and parking areas, shall remain privately owned and maintained in perpetuity. The HOA/POA shall limit the number of rental units to 10% of the total homes constructed.
- 10) Parking areas shall be provided so that the principal entrance of each dwelling unit is no further than 200 feet from such area. The orientation of dwellings and parking areas shall be provided so that parking areas are provided on the side or rear of the development and/or are accessible via alleys. Alleys, subject to applicable fire code and Land Development requirements, are encouraged.
- 11) Any streets designated as such shall be built to public street standards and shall have landscaping and streetscaping on both sides of curb as per new street requirements in Section 5.4.3. Any alleys designated as such shall have a minimum five (5)-foot sidewalk and landscape strip provided on at least one-side. Sidewalks may be provided to the back of off-street parking spaces.
- 12) A minimum of 20 percent of the development site shall be open space.
- 13) Approval of this rezoning application by the Board of Commissioners has no bearing on the requirements for other regulatory approvals under the authority of the Planning Commission, the Zoning Board of Appeals, or other entity whose decision should be based on the merits of the application under review by each entity.

**DeKalb County Department of Planning & Sustainability**

**178 Sams Street,  
Decatur, GA 30030**

**(404) 371-2155 / [www.dekalbcountyga.gov/planning](http://www.dekalbcountyga.gov/planning)**

**Planning Commission Hearing Date: Tuesday, March 5, 2024  
Board of Commissioners Hearing Date: Thursday, May 23, 2024**

**STAFF ANALYSIS**

<b>Case No.:</b>	CZ-23-1246630	<b>Agenda #:</b> 2023-1142
<b>Location/Address:</b>	1484 and 1520 Columbia Drive Decatur, GA 30032	<b>Commission District:</b> 03 <b>Super District:</b> 07
<b>Parcel ID(s):</b>	15-186-04-028 & 15-186-04-029	
<b>Request:</b>	Major modification to zoning conditions pursuant to Z-22-1245596 to increase the number of units and construct a single-family cottage development within the R-60 (Residential Small Lot-60) Zoning District.	
<b>Property Owner(s):</b>	Kova Real Estate LLC	
<b>Applicant/Agent:</b>	Stix and Stones Homes	
<b>Acreage:</b>	2.73 acres	
<b>Existing Land Use:</b>	Vacant	
<b>Surrounding Properties:</b>	<b>North:</b> R-75 <b>East:</b> R-75 <b>South:</b> R-75 <b>West:</b> MR-2 and R-75	
<b>Comprehensive Plan:</b>	<b>Suburban (SUB)</b> <b>Consistent</b> <input checked="" type="checkbox"/> <b>Inconsistent</b> <input type="checkbox"/>	

**Staff Recommendation: APPROVAL WITH CONDITIONS**

The subject properties were rezoned from the R-75 (Residential Medium Lot-75) Zoning District to the R-60 (Residential Small Lot-60) zoning district on July 26, 2022 (Z-22-1245596). This rezoning was approved with conditions that restricted the development site to no more than 11 single-family detached dwellings (see enclosed conditions, site plan, and other approved documents).

The applicant proposes a major modification to modify Conditions #1 and #2 to allow for up to 16 single-family, fee-simple, cottage dwellings at a density of approximately 5.9 units per acre. The proposed cottage development is a permitted principal use in the R-60 Zoning District, subject to design regulations in Section 5.7.9. of the *Zoning Ordinance*, which was added as a text amendment by the Board of Commissioners on December 12, 2023.

The original site plan with the proposal, dated August 24, 2023 and titled “*Columbia Cottages*”, showed clusters of cottage dwellings centered around several courtyards which qualify as areas of enhanced open space typical of cottage developments. This site plan, however, contained numerous zoning deficiencies,

including a lack of streetscaping, lot compatibility, and compliance with cottage development standards that were in place at the time. Significant deficiencies with proposed stormwater detention facilities were noted by Land Development, Roads and Drainage, and Watershed. As a result, at its meeting on November 16, 2023, the Board of Commissioners granted this case a *two-cycle deferral* to give the applicant sufficient time to redesign their proposal.

A revised site plan dated January 17, 2024 showed an updated design that addressed a majority of concerns raised by Planning Staff with the initial submittal. On February 15, 2024, a roundtable discussion was held with the applicant and other County departments; many of the previous deficiencies were deemed to be adequately addressed with the new proposal including underground stormwater detention. However, some concerns regarding the location of certain units and the distance from proposed off-street parking were raised by the Planning Commission at their meeting held on March 5, 2024.

A third plan was submitted in response to these concerns on March 8, 2024. This plan relocates several of the proposed cottage units to be closer to Columbia Drive and reorients the overall development to be centered on a central common area that is perpendicular to the aforementioned right-of-way. The units and parking areas are located so that no unit is more than 200 feet from an off-street parking space, as required per Section 5.7.9. (F) of the *Zoning Ordinance*.

From a land use and density perspective, the proposed single-family cottages appear to be consistent with the following strategies and policies of the Suburban Character Area policy of the *DeKalb County 2050 Unified Plan*: “Permit cottage court developments, accessory housing units, new well-designed, small-scale infill multi-family residences and other innovative housing types to increase housing choice, income diversity, and limited neighborhood density” (pg. 39). An increase in density may be appropriate on this property, which fronts a minor arterial road between commercial nodes located approximately 1,800 feet to the north (Columbia Drive/Belvedere Lane) and approximately 1,900 feet to the south (Columbia Drive/Peachcrest Road). Furthermore, an appropriately designed cottage subdivision with maximum building heights of one-and-a-half stories and unit sizes not exceeding 1,200 square feet would not be expected to adversely affect the existing character of uses in the general vicinity, which are primarily single-family dwellings of similar height and size. Therefore, upon review of Section 7.3.5., the Department of Planning and Sustainability recommends *approval with conditions*.

CZ-23-1246630

Major Modification of Conditions Pursuant to Z-22-1245596

Staff Recommended Conditions

03/15/2024

1484 and 1520 Columbia Drive

Decatur, GA 30032

- 1) ~~The development shall have a maximum of eleven (11), detached, single-family homes. General compliance with the site plan received May 3, 2022, shall be required. The community must establish a homeowners' or property owners' association (HOA or POA) per the Zoning Ordinance and Land Development Code. The HOA/POA shall limit the number of rental units to 10% of the total homes constructed.~~ The development site shall be improved with no more than sixteen (16) fee-simple single-family detached cottages. Unit sizes shall not exceed 1,200 square feet of heated floor area. The proposed alignment of dwellings and other improvements shall conform with all standards of Section 5.7.9. of the *Zoning Ordinance*. Proposed cottages shall be located and centered around a common area of enhanced open space in general conformance to that shown on the site plan dated 03/08/2024, and titled "Columbia Cottages". The site plan is conceptual, however, and the location of the dwelling units may be altered to better support other required improvements, such as off-street parking, open space, and stormwater detention facilities subject to approval of the Planning Director. All dwelling units shall be within 60 feet walking distance along the shortest safe walking route to the nearest point of the common open space.
- 2) All home designs shall be consistent with the enclosed color rendering(s) ~~entitled "2021-12-20-11-10-43,"~~ dated 10/25/2023, including the following building materials: cementitious hardie plank, vinyl glass windows, shingle ~~roofing~~ or metal roofs over porches, ~~stained cedar plank for post beams and gable crosses, and vinyl garage doors,~~ and must comply with the applicable provisions of ~~Article 5 of the Zoning Ordinance~~ Section 5.7.9. of the *Zoning Ordinance* related to building form and design.
- 3) The developer shall construct at least one stacked stone, monument subdivision sign on the community property along Columbia Drive. Signage shall comply with applicable sections of the *Sign Ordinance*.
- 4) Signs shall be posed inside the community and at the curb cut on Columbia Drive to indicate that the southernmost driveway is one-way only into the property.
- 5) A 10-foot sidewalk/multimodal path shall be provided in County right-of-way along the entirety of the development site's frontage on Columbia Drive. A minimum of 10 feet of landscaping shall be provided in the right-of-way, subject to the requirements of Section 5.4.3. Street trees and street lights shall preferably be provided in a landscape strip between the back of curb and multimodal path. Reductions of these requirements may be granted if there are conflicts with existing utility or overhead power lines, topography, or other site conditions as determined by the Planning Director.

- 6) Independent of the landscaping required in the right-of-way per Section 5.4.3., additional landscaping may be required in the front yard of the development site subject to the discretion of the Planning Director. A three (3) foot tall picket or wrought-iron fence shall be provided in the required front yard adjacent to any dwelling units.
- 7) A minimum ten (10) foot natural or landscaped buffer shall be provided around the perimeter of all property lines not subject to streetscape requirements, with the exception of property lines adjacent to any street, alley, or parking areas, for which a five (5)-foot minimum buffer is required. A six (6) foot high opaque fence shall be required along all interior property lines, with the exception that no such fence shall be provided within the required front yard of the development site – along interior lines within this front yard, trees and shrubs shall be planted to provide a vegetative screen.
- 8) At least two (2) pedestrian paths (measuring five (5) feet in width) shall be provided connecting the main common area to the sidewalk/multimodal path along Columbia Drive. Additional connections may be required, subject to the discretion of the Planning Director.
- 9) A homeowners' association or property owners' association (HOA or POA) shall be created to ensure proper maintenance and funding of shared facilities. All areas/facilities interior to the development site, such as stormwater facilities, detention ponds, open spaces, streets, alleys, and parking areas, shall remain privately owned and maintained in perpetuity. The HOA/POA shall limit the number of rental units to 10% of the total homes constructed.
- 10) Parking areas shall be provided so that the principal entrance of each dwelling unit is no further than 200 feet from such area. The orientation of dwellings and parking areas shall be provided so that parking areas are provided on the side or rear of the development and/or are accessible via alleys. Alleys, subject to applicable fire code and Land Development requirements, are encouraged.
- 11) Any streets designated as such shall be built to public street standards and shall have landscaping and streetscaping on both sides of curb as per new street requirements in Section 5.4.3. Any alleys designated as such shall have a minimum five (5)-foot sidewalk and landscape strip provided on at least one-side. Sidewalks may be provided to the back of off-street parking spaces.
- 12) A minimum of 20 percent of the development site shall be open space.
- 13) Approval of this rezoning application by the Board of Commissioners has no bearing on the requirements for other regulatory approvals under the authority of the Planning Commission, the Zoning Board of Appeals, or other entity whose decision should be based on the merits of the application under review by each entity.



# SITE INFORMATION

**LOCATION:**  
 ADDRESS: 1484 COLUMBIA DR  
 DECATUR, GA  
 LAND LOT: 186  
 DISTRICT: 15TH  
 COUNTY: DEKALB  
 CURRENT ZONING: R - 60  
 PROPOSED ZONING: R - 60  
 SITE AREA: 121,750 SF (2.794 ACRES)

**OVERALL SITE REQUIREMENTS:**  
 MAXIMUM DWELLINGS PER ACRE: 6  
 DWELLING UNITS PROVIDED: **16 TOTAL**  
 LOT COVERAGE (35% \* 121,750) : 42, 613 SF  
 MAXIMUM DWELLING UNITS: 30  
 MINIMUM DWELLING UNITS: 4

**PROPOSED BUILDING SETBACKS:**  
 FRONT YARD (COLUMBIA DRIVE): NONE  
 FRONT YARD (ALLEY): NONE  
 INTERIOR SIDE YARD (MIN.): NONE  
 REAR YARD: NONE

**COTTAGE SIZE**  
 SF DETACHED - COTTAGE (MIN.): 800 SF  
 SF LOTS - CURRENTLY: 3,500 SF  
 BUILDING HEIGHT: 22' - 0"

**PARKING**  
 PARKING REQUIRED: 1 PER UNIT (.25 GUEST)  
 COMMON PARKING PROVIDED: 34  
 GUEST PARKING PROVIDED: 4  
 TOTAL SPACES PROVIDED: 38

PARKING LOT DISTANCES: - - - - -

**OPEN ENHANCED SPACE**  
 OPEN SPACE PROVIDED: 31,004 SF

○ SITE INFORMATION  
 1/4" = 1'-0"



① 0 - Site Plan - R-60 Zoning - REV 05  
 1" = 30'-0"

**REVISED SITE PLAN**  
**03/28/2014**

NOT RELEASED FOR CONSTRUCTION



# COLUMBIA COTTAGES

1484 COLUMBIA DRIVE | DECATUR | 30032

XMETRICAL, LLC | Modern Design Studio | 834 Inman Village Pkwy Suite 140 | Atlanta 30307 | 404.474.2204 | office@xmetrical.com

THIS DRAWING, ITS CONTENTS AND ALL PRINTS OF IT ARE THE PROPERTY OF XMETRICAL, LLC. ANY USE OF THIS DOCUMENT FOR PURPOSES OTHER THAN THOSE ASSOCIATED WITH THIS SPECIFIC PROJECT OR ANY REPRODUCTION OF THIS DRAWING WITHOUT THE WRITTEN CONSENT OF XMETRICAL, LLC IS STRICTLY PROHIBITED.

No.	Description	Date
1	CONCEPT SITE PLAN	2024.03.08

CECIL FRANCIS

## ARCHITECTURAL SITE PLAN - REV

Project number	05	452
Date	2023.01.01	
Drawn by	J.K.AVERY	
Checked by	J.K.AVERY	

**A100.4**

Scale: As indicated

# SITE INFORMATION

**LOCATION:**  
ADDRESS: 1484 COLUMBIA DR  
DECATUR, GA  
LAND LOT: 186  
DISTRICT: 15TH  
COUNTY: DEKALB  
CURRENT ZONING: R - 60  
PROPOSED ZONING: R - 60  
SITE AREA: 121,750 SF (2.794 ACRES)

**OVERALL SITE REQUIREMENTS:**  
MAXIMUM UPPERMOUNTING HEIGHT: 30'  
MAXIMUM NUMBER OF UNITS PER LOT: 1  
MAXIMUM NUMBER OF UNITS PER ACRE: 1  
MAXIMUM LOT AREA: 10,000 SF  
MAXIMUM BUILDING HEIGHT: 22'-0"

**PROPOSED BUILDING SETBACKS:**  
FRONT YARD (COLUMBIA DRIVE): NONE  
FRONT YARD (ALLEY): NONE  
INTERIOR SIDE YARD (MIN.): NONE  
REAR YARD: NONE

**COTTAGE SIZE**  
SF DETACHED - COTTAGE (MIN.): 800 SF  
SF LOTS - CURRENTLY: 3,500 SF  
MAXIMUM BUILDING HEIGHT: 22'-0"

**PARKING**  
PARKING REQUIRED: 1 PER UNIT (.25 GUEST)  
COMMON PARKING PROVIDED: 15  
GUEST PARKING PROVIDED: 4  
**TOTAL SPACES PROVIDED:** 33

**OPEN ENHANCED SPACE**  
OPEN SPACE REQUIRED: 24,350  
OPEN SPACE PROVIDED: 27,316



1 SITE INFORMATION  
1/4" = 1'-0"

0 - Site Plan - 3500 SF LOT R-60 Zoning -  
REV 02  
1" = 30'-0"

NOT RELEASED FOR CONSTRUCTION



# COLUMBIA COTTAGES

1484 COLUMBIA DRIVE | DECATUR | 30032

XMETRICAL, LLC | Modern Design Studio | 834 Inman Village Pkwy Suite 140 | Atlanta 30307 | 404.474.2204 | office@xmetrical.com

THIS DRAWING, ITS CONTENTS AND ALL PRINTS OF IT ARE THE PROPERTY OF XMETRICAL, LLC. ANY USE OF THIS DOCUMENT FOR PURPOSES OTHER THAN THOSE ASSOCIATED WITH THIS SPECIFIC PROJECT OR ANY REPRODUCTION OF THIS DRAWING WITHOUT THE WRITTEN CONSENT OF XMETRICAL, LLC IS STRICTLY PROHIBITED.

No.	Description	Date
1	CONCEPT SITE PLAN	2024.01.17

CECIL FRANCIS

## ARCHITECTURAL SITE PLAN - 0

Project number: 452  
Date: 2023.01.01  
Drawn by: J.K.AVERY  
Checked by: J.K.AVERY

# A100.0

Scale: As indicated

# REVISED SITE PLAN, 01/17/2024

# SITE INFORMATION

**LOCATION:**  
 ADDRESS: 1484 COLUMBIA DR  
 DECATUR, GA  
 LAND LOT: 186  
 DISTRICT: 15TH  
 COUNTY: DEKALB  
 CURRENT ZONING: R - 60  
 PROPOSED ZONING: R - 60  
 SITE AREA: 121,750 SF (2.794 ACRES)

**OVERALL SITE REQUIREMENTS:**  
 DWELLINGS PER ACRE: 12  
 DWELLING UNITS PROVIDED: 20 TOTAL (7.3 PER ACRE)  
 LOT COVERAGE (35% \* 121,750) : 42, 613 SF

**PROPOSED BUILDING SETBACKS:**  
 FRONT YARD (COLUMBIA DRIVE): 20' - 0" (EXISTING)  
 FRONT YARD (ALLEY): 7' - 0" (EXISTING)  
 INTERIOR SIDE YARD (MIN.): 3' - 0" (7'-6" EXISTING)  
 REAR YARD: 10' - 0" (30' - 0" EXISTING)

**COTTAGE SIZE**  
 SF DETACHED - COTTAGE (MIN.): 800 SF  
 SF LOTS - CURRENTLY: 3,500 SF  
 BUILDING HEIGHT: 35' - 0"

**PARKING**  
 PARKING REQUIRED: 2 PER UNIT (41 TOTAL)  
 COMMON PARKING PROVIDED: 23  
 ON-LOT PARKING PROVIDED: 18  
 TOTAL SPACES PROVIDED: 41

SITE INFORMATION  
 1/4" = 1'-0"

**COMPLIANCE WITH DISTRICT STANDARDS (SINGLE FAMILY COTTAGE):**

R-60 STANDARD	REQUIRED/ALLOWED	PROPOSED
MIN. LOT AREA	6000 SF	3,500 SF
MIN. LOT WIDTH	NONE	VARIES
MIN. LOT WIDTH - NEW CORNER LOT	NONE	VARIES
MIN. YARD SETBACKS	FRONT	20 feet
	CORNER LOT - SIDE	20 feet
	INTERIOR LOT - SIDE	7.5 feet
	REAR	30 feet
MAX. HEIGHT	1.5 stories	1.5 stories
MIN. FLOOR AREA OF	800-1,200 SF	800-1,200 SF
PARKING	2 spaces per dwelling unit (40)	(41) Provided
STREETSCAPE-COLUMBIA DRIVE	(Minimums) 6-foot landscape Strip back of curb, 10 foot wide Sidewalk, street trees every 50 feet, light poles every 80 feet.	(Minimums) 6-foot landscape Strip back of curb, 10 foot wide Sidewalk, street trees every 50 feet, light poles every 80 feet.

0 - Site Plan - 3500 SF LOT R-60 Zoning  
 Copy 1  
 1" = 30'-0"



**ORIGINAL SITE PLAN, 08/24/2023**

NOT RELEASED FOR CONSTRUCTION



# COLUMBIA COTTAGES

1484 COLUMBIA DRIVE | DECATUR | 30032

xMETRICAL, LLC | Modern Design Studio | 834 Inman Village Pkwy Suite 140 | Atlanta 30307 | 404.474.2204 | office@xmetrical.com

THIS DRAWING, ITS CONTENTS AND ALL PRINTS OF IT ARE THE PROPERTY OF XMETRICAL, LLC. ANY USE OF THIS DOCUMENT FOR PURPOSES OTHER THAN THOSE ASSOCIATED WITH THIS SPECIFIC PROJECT OR ANY REPRODUCTION OF THIS DRAWING WITHOUT THE WRITTEN CONSENT OF XMETRICAL, LLC IS STRICTLY PROHIBITED.

No.	Description	Date
1	CONCEPT SITE PLAN	2023.08.22

CECIL FRANCIS

ARCHITECTURAL SITE PLAN

Project number 452  
 Date 2023.01.01  
 Drawn by J.K.AVERY  
 Checked by J.K.AVERY

**A100**

Scale As indicated

Save changes

1484 columbia Cotta... - Editing



Save changes

1484 Columbia Cotta... - Editing



Save changes

1484 columbia Cotta... - Editing



**AN ORDINANCE TO AMEND  
CHAPTER 27 OF THE CODE OF DEKALB COUNTY, GEORGIA,  
AND FOR OTHER PURPOSES.**

**WHEREAS**, the Board of Commissioners is authorized to exercise zoning powers to protect and promote the County's health, safety, and general welfare; and;

**WHEREAS**, single-family cottage developments can encourage a stronger sense of community, promote stronger variety of housing choice and encourage affordability;

**WHEREAS**, the County desires to encourage the development of cottage housing by amending the regulations around cottage housing; and

**WHEREAS**, cottage style development can represent a valuable housing tool to promote more efficient use of existing residentially zoned land for infill development, capture contemporary innovative housing design at smaller sizes than currently permitted, and potentially reduce home construction costs.

**NOW THEREFORE, BE IT ORDAINED** by the Governing Authority of DeKalb County, Georgia, and be it hereby ordained by the Authority of same, that Chapter 27 of the Code of DeKalb County, as revised 1988, is hereby amended as follows.

**PART I. ENACTMENT**

*By amending Section 2.2.1, Table 2.2; Section 2.11.2, Table 2.4; Section 2.18.3, Table 2.17; Section 4.1.3, Table 4.1; Section 5.7.5; Section 5.7.9; Section 6.1.4, Table 6.2; and Section 9.1.3 of Chapter 27, of the Code of DeKalb County, as revised 1988, as follows:*

**Sec. 2.2.1. Dimensional requirements.**

Dimensional requirements, such as overall site requirements, individual lot dimensions, and setbacks for residential zoning districts are established in Table 2.2, "Residential Zoning Districts Dimensional Requirements." Residential infill development may also be subject to compatibility regulations as specified in sections 5.2.3 and 5.2.4.

**Table 2.2 Residential Zoning Districts Dimensional Requirements**

<b>Residential Single-Family Zoning Districts</b>								
<b>KEY:</b> Housing Types: SF: Single-Family, TF: Two-Family, TRF: Three-Family, MF: Multi-Family Character Areas: RC: Regional Center, TC: Town Center, NC: Neighborhood Center, SUB: Suburban								
<b>Element</b>	<b>RE</b>	<b>RLG</b>	<b>R-100</b>	<b>R-85</b>	<b>R-75</b>	<b>R-60</b>	<b>MHP</b>	<b>RNC*</b>
<b>Lot Dimensions (minimum)</b>								
Lot area (square feet)	43,560 (1 acre)	20,000	15,000	12,000	10,000	6,000	Parks: 20 acres Lots: 4,000	*
<b>Unit Size, heated living area (minimum)</b>								
Unit size (square feet)	2,000	2,000	2,000	1,800	1,600	1,200/350 cottage	N/A	*

\* See division 10 of this article

\*\*\*

**Sec. 2.11.2. - Dimensional requirements.**

Dimensional requirements, including overall site requirements, individual lot dimensions, setbacks, and heights for Medium and High Density Residential Zoning Districts, are provided in Table 2.4, "Medium and High Density Residential Zoning Districts Dimensional Requirements." In addition, compatibility and transitional buffers as defined and required in article 5 may apply.

**Table 2.4 Medium and High-Density Residential Zoning Districts Dimensional Requirements.**

<b>Medium and High Density Residential</b>					
<b>KEY:</b> Housing Types: SFD: Single-Family Detached, SFA: Single-Family Attached, TTF: Two/Three-Family, MF: Multi-Family, MU: Mixed-Use, U-SF: Urban Single-Family Character Areas: RC: Regional Center, TC: Town Center, TN: Traditional Neighborhood, NC: Neighborhood Center, SUB: Suburban					
<b>Elements</b>	<b>RSM</b>	<b>MR-1</b>	<b>MR-2</b>	<b>HR-1</b>	<b>HR-2 and HR-3</b>



Overall Site Requirements (minimum, unless otherwise specified)					
Dwelling units per acre (maximum base density and maximum possible with bonuses)	4—8	8—12	12—24	24—40	HR-2: 40—60 HR-3: 60—120
Lot Requirements (minimum, unless otherwise specified)					
Single-Family Detached Conventional (SFD)**					
Lot area (square feet)	5,000	5,000	5,000	Not permitted	Not permitted
Lot width, street frontage (feet)	50/20 detached townhome	45/20 detached townhome	40/20 detached townhome	Not permitted	Not permitted
Unit Size, heated living area (square feet, minimum)					
Single-Family Detached (SFD)- Cottage	350	350	350	Not permitted	Not permitted

\*\*\*

**Sec. 2.18.3. Mixed-Use dimensional requirements.**

Dimensional requirements including overall site requirements, individual lot dimensions, setbacks, and heights for Mixed-Use Districts are provided in Table 2.17, "Mixed-Use Zoning Districts Dimensional Requirements." Compatibility rules and transitional buffers as defined and required in article 5 may apply.

**Table 2.17 Mixed-Use Zoning Districts Dimensional Requirements.**

Mixed-Use Districts				
KEY: Development Types: SFD: Single-Family Detached, SFA: Single-Family Attached, TTF: Two/Three-Family, MF: Multi-Family, U-SF: Urban Single-Family, MU: Mixed-Use, CM: Commercial, OF: Office Character Areas: SUB: Suburban, TN: Traditional Neighborhood, NC: Neighborhood Center, TC: Town Center, RC: Regional Center				
Element	MU-1	MU-2	MU-3	MU-4 and MU-5
Overall Site Requirements (minimum, unless otherwise specified)				
Dwelling units per acre (with bonus)	4—8	8—12	12—24	MU-4=24—40;

				MU-5=40— 60
<b>Individual Lot Dimensions by Residential Type (minimum, unless specified)</b>				
<b>Single-Family Detached (SFD) **</b>				
Lot area (square feet)	3,500	3,500	3,500	Not permitted
Lot width (feet)	35	35	35	16
<b>Unit Size, heated living area (minimum, unless specified)</b>				
Single-Family Detached (square feet)	1,200 / 350 cottage	1,200 / 350 cottage	1,200 / 350 cottage	Not permitted

\*\* SFD Cottage type exempt; see article 5 for standards

\*\*\*

**Sec. 4.1.3. Use table.**

KEY:	P - Permitted use												
	Pa - Permitted as an accessory use												
Use	RE	RLG	R-100	R-85	R-75	R-60	RSM	MR-1	MR-2	HR-1,2,3	MHP	RNC	
<b>RESIDENTIAL</b>													
<b>Dwellings</b>													
Dwelling, cottage home						P	P	P	P				P

KEY:	SA - Special administrative permit from Director of Planning													
	SP - Special land use permit from BoC (SLUP)													
Use	OI	OIT	NS	C-1	C-2	OD	M	M-2	MU-1	MU-2	MU-3	MU-4,5	See Section 4.2	
<b>RESIDENTIAL</b>														
<b>Dwellings</b>														
Dwelling, cottage home									P	P	P		✓	

\*\*\*

**Section 27-5.7.5. – Detached houses.**

- A. This section shall apply to the following housing types:
  1. *Conventional single-family detached.* A development with one (1) dwelling unit per lot of record with private yards on all four (4) sides.
  2. *Urban single-family detached.* A development with single-family detached dwelling units located on small lots. Urban single-family (Urban-SF) residential buildings share similar configurations to townhouse developments; however, they are detached and may have lot lines that coincide with the building envelope, provided that a yard area is provided in the dimensions required by the zoning district.
- B. Dimensional and use requirements. Minimum lot size, width, and setbacks shall meet the dimensional requirements set forth for the applicable base zoning district in article 2.

- C. Orientation.
1. Lots along the perimeter of a development of single family detached residences shall be oriented so that dwellings front internal local streets instead of a thoroughfare. Lots with rear yards abutting a thoroughfare shall provide a ten-foot no access easement and: a twenty-foot landscape strip, a six-foot-high decorative fence, or a five-foot-high landscaped berm to screen the rear view of houses from the thoroughfare.
  2. Street frontage requirements in section 14-258 of the Code shall not apply to individual lots within an urban type residential development provided the overall site complies with minimum street frontage requirements and an alley or private drive provides access directly to a public street.
- D. Each dwelling unit shall be metered for water individually.
- E. An easement for water and sewer shall be required and subject to the approval of the watershed division of the public works department.
- F. Access driveway, internal private drive and alley standards.
1. Urban residences shall have vehicular access from the rear of the property from an alley or similar private drive, or may have an off-street parking area located on the side or rear of the development. Such parking area may not occupy more than thirty (30) feet of frontage and be located no more than two hundred (200) feet from the unit's entrance. The alley shall be at least twenty (20) feet in width and meet the standards of International Fire Code (IFC) 503, unless another width is approved by the director for one-way direction only.
  2. Single-family detached residences may share a driveway serving two (2) lots, provided that the width of the driveway at the street shall not exceed the width requirements established in chapter 14 of the Code, and that the driveway width not increase for the first ten (10) feet of drive.
- G. Urban single-family dwellings may gain access through private drives that meet the standards of section 5.6.7C.4.
- H. Driveways shall not exceed ten (10) feet between garage door and sidewalk.
- I. Conventional, single-family, detached residences shall follow the size requirements set forth in article 2.
- J. Architectural variability.
1. Residential subdivisions of three (3) or more lots intended for conventional single-family detached residences shall include distinctly different front façade designs within each phase of the development. "Distinctly different" shall mean that each front façade must differ from adjacent buildings' front façades in at least four (4) of the following six (6) ways:
    - a. The use of different primary exterior materials;
    - b. Variation in the width or height of the front façade by four (4) feet or more;

- c. Variation of the type, placement or size of windows and doors on the front façades;
  - d. Variations in rooflines, including the use of dormers and changes in the orientation of rooflines;
  - e. Variation in the location and proportion of front porches; and
  - f. Variation in the location or proportion of garages and garage doors.
2. No conventional single-family detached residence shall be of the same front façade design as any other conventional single-family detached residence along the same block face within eight (8) lots of the subject residence. Mirror images of the same configuration are not permitted on the same block face.
  3. No single front façade design may be used for more than twenty-five (25) percent of the total units of any single phase of a conventional single-family detached residence subdivision.
  4. This subsection shall not apply to single family cottage homes.
- K. Porches and stoops. Any porch shall have minimum dimensions of four (4) feet by eight (8) feet for porches, and any stoop shall have minimum dimensions of and four (4) feet by four (4) feet. Porches and stoops shall be no closer than two (2) feet from a utility easement.
- L. Façades. Any conventional single-family detached residence with a front façade width of forty (40) feet or more shall incorporate wall offsets in the form of projections or recesses in the front façade plane. Wall offsets shall have a minimum depth or projection of two (2) feet so that no single wall plane exceeds twenty-five (25) feet in width.
- M. Roof and overhangs. Conventional single-family detached residences shall incorporate the following standards:
1. Roofs covering the main body of the structure shall be symmetrical gables, hip-style, or mono-pitch (shed) style.
  2. Mono-pitch roofs shall have a minimum pitch of 4:12, and all other roofs covering the main body of a detached house shall have a minimum roof pitch of 6:12.
  3. Overhanging eaves shall extend at least twelve (12) inches beyond the exterior wall.
  4. To the maximum extent practicable, all roof vents, pipes, antennas, satellite dishes, and other roof penetrations and equipment (except chimneys) shall be located on the rear façades or configured to have a minimal visual impact as seen from an adjacent street.
- N. Garages. The following standards shall apply:
1. Street-facing garage façades shall not comprise more than forty-five (45) percent of the total width of the conventional single family detached residence's front façade. Street-facing garages shall be at least two (2) feet behind the primary front façade plane of a conventional single-family detached residence.

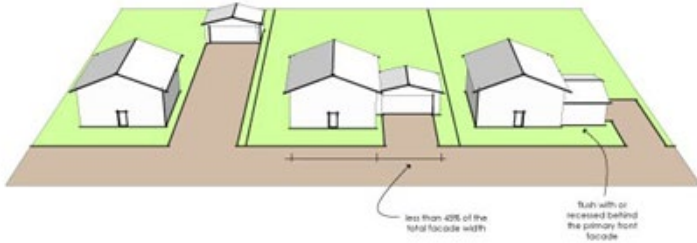

*Acceptable garage configurations*

- O. Clubhouse/pool amenity areas, greens, playgrounds, pocket parks, neighborhood parks, or detention facilities designed to serve as amenities shall meet dimensional requirements in the base zoning district (article 2) and the standards of article 5, division 5, open space standards.

\*\*\*

**Section 27-5.7.9. – Single-Family, Cottage Development.**

- A. The purpose of single-family, cottage development design is to:

1. Encourage a stronger sense of community and security among nearby neighbors, while preserving personal privacy;
2. Promote a variety of housing choices to meet the needs of a population diverse in age, income, household composition and individual needs; especially small households (one to three-person households);
3. Encourage affordability, innovation and variety in housing design and site development while ensuring compatibility with surrounding land uses;
4. Encourage the creation of more usable open space for residents of the development through flexibility in density and lot standards;
5. Maximize resident- and pedestrian-oriented outdoor spaces, and minimize impact of automobile traffic and parking.

- B. This section shall apply to this specific housing development style: cottage development (also referred to as a “single-family, cottage development”). A development with small, single-family, detached dwelling units that are one (1), one and one-half (1.5) and/or two (2) stories arranged whereby they are clustered around an enhanced open space with a mandatory homeowners’ association that maintains the common shared space and other common elements.

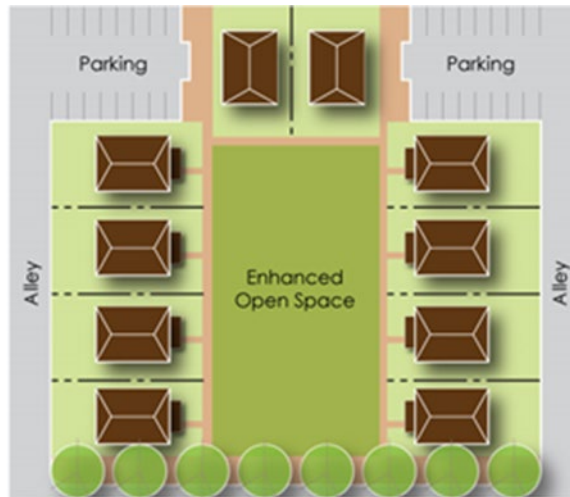

Figure 5.7.9A

- C. Use Restrictions. Cottage homes shall be owner-occupied only. Multi-family dwelling units (including duplexes, triplexes, etc.) and short-term rental services are not permissible in this living arrangement. Accessory dwelling units are not permitted.
- D. Development Standards.
1. Development Arrangement shall consist of one of two forms (no mixing):
    - a. A development with each proposed dwelling unit on an individual lot; or
    - b. A development with multiple dwelling units on a single lot with a condominium ownership arrangement.
  2. Individual lots or building sites within the cottage development are exempt from the base zoning district standards for lot area, lot width, setbacks, and lot coverage. However, lot area, lot width, setbacks, and lot coverage apply to the overall cottage development parcel. A minimum of 20% of total site area shall be reserved for open space. Maximum lot coverage for the total cottage development shall not exceed 60%. Dwelling units oriented toward the common open space area shall provide a five-foot minimum setback from the common area. Such setback does not count toward any required common area.
  3. Nothing herein shall preclude the combination of multiple, contiguous lots to achieve the minimum required lot area. The minimum total lot area required for a cottage development is determined by calculating the cumulative lot area required by the base zoning district for the number of dwelling units to be constructed and reducing the result by 50%. For example, 4 cottage dwelling units under RSM zoning (minimum 5,000sf lot area) equals a minimum total lot area of 10,000sf  $((4 \times 5,000\text{sf}) \times 0.50 = 10,000\text{sf})$ .
  4. A cottage development shall consist of a minimum of four (4) and no more than thirty (30) dwelling units. Within the aforementioned range, the maximum number of dwelling units per acre shall be determined by the future land use character area and any applicable bonus density.

5. Cottage unit size shall be no less than 350 square feet and shall not exceed twelve hundred (1,200) square feet, heated living area.
  6. Separation distance between buildings shall be no less than ten (10) feet. However, this distance may be decreased to six (6) feet if the enhanced open space is increased by an equivalent or greater amount.
  7. Single-family cottage lots or home sites shall be oriented toward the enhanced open space or a street. Street frontage requirements of Section 14-258 of the *Land Development Code (Chapter 14)* shall not apply to individual lots within a cottage development provided the overall site complies with minimum street frontage requirements and an alley or private drive provides access from parking area(s) directly to a public street.
- F. Required off-street parking may be provided on individual lots for each dwelling unit within the cottage development or in a shared parking area serving multiple dwellings on-site. Parking shall not be located between principal structures and the street, or within any common open space area. Single-family, cottages shall have vehicular access from the rear of the property from an alley or similar private drive or may have an off-street parking area located on the side or rear of the development. Such parking area may not occupy more than thirty (30) feet of frontage and be located no more than two hundred (200) feet from the unit's entrance. Use of alleys, subject to applicable fire code requirements, is encouraged.
- G. Porches. Any porch shall have minimum dimensions of four (4) feet by eight (8) feet for porches, and any stoop shall have minimum dimensions of and four (4) feet by four (4) feet. Porches and stoops shall be no closer than two (2) feet from a utility easement.
1. Additional Porch Requirements on single-family, cottages:
    - a. Location. Every dwelling shall have a covered entry porch oriented toward the common open space or street. This porch shall be open on at least two sides and shall not be enclosed. Screened-in porches are acceptable. Back and side, wrap porches allowed and encouraged.
    - b. Size. The covered porch shall be greater than 70 square feet in area, with a minimum of dimension of 6 feet in depth.
      - i. Exception: Dwellings less than 700 square feet in size may have a porch greater than 50 square feet in area and 5 feet minimum dimension.
- H. Façades. Any residence with a front façade width of twenty-five (25) feet or more shall incorporate wall offsets in the form of projections or recesses in the front façade plane. Wall offsets shall have a minimum depth or projection of at least two (2) feet.
1. Street-Facing Facades. All street-facing facades of dwellings shall avoid blank walls and include a porch with one or more of the following elements, features, or treatments:

- a. Windows (including bay windows) or other fenestration;
- b. Dormers;
- c. Changes in exterior material or paint color;
- d. Building modulation/articulation with a depth measuring at least one foot; or
- e. Entry enhancements (e.g., multi-panel door).

I. Central enhanced open space.

- a. Single-family, cottages shall be clustered around an enhanced open space green that is a minimum of three thousand (3,000) square feet or four hundred (400) square feet per cottage served by the enhanced open space, whichever is greater.
- b. The enhanced open space green shall have a minimum dimension of twenty (20) feet on each side.
- c. At least two (2) sides of the enhanced open space green shall have cottages along its perimeter.
- d. Accessory structures, serving all residents in the cottage development, may be included in the required area. No more than 30% of the common enhanced open space area shall be impervious.
- e. Parking areas, yard setbacks, spaces between buildings of 15 feet or less in width, private open space, and driveways do not qualify as common open space.
- f. Proximity to Enhanced Open Space. At least 75 percent of the dwelling units of a cottage development shall abut an enhanced common open space; and all of the dwelling units shall be within sixty (60) feet walking distance (measured from the nearest entrance of the dwelling along the shortest safe walking route to the nearest point of the common open space).
- g. Cottage lots or homesites shall be planted with a minimum of one (1) new 2.5" caliper canopy tree or alternatively three (3) understory trees.

J. Additional Cottage Development Elements:

- 1. Community Buildings and Elements.
  - a. Every cottage development shall contain at least two of the following elements (under common ownership):
    - i. Barbeque grill, pizza oven, or outdoor terrace;
    - ii. Picnic table(s) and/or shelter;
    - iii. Community building (built in residential form);
    - iv. Kitchen garden, flower garden, or productive urban landscape; or
    - v. Other community element as approved by Director of Planning.
- 2. Fences. Fences are not required, but if installed, then the following requirements shall apply:
  - a. Fence height requirements:
    - i. Front yard: maximum 24-inch height



- ii. Side yard: maximum 36-inch height when located from property line to face of dwelling, and maximum 72 inches (6 feet) behind the face of dwelling for open slat fences only;
    - iii. Rear yard: maximum 72 inches for open slat fences only
    - iv. Street Facing: maximum 36-inch height.
  - b. Permitted materials include: wood, metal (excluding chain link), vinyl, or fiberglass.
  - c. Hedges shall be limited to the same height requirements as subsection K2a above.
- 3. Pedestrian Network. Cottage developments shall provide a network of pedestrian pathways, including sidewalks along at least one side of streets, mid-block walkways, and shared local streets and access alleyways. Connections to the wider neighborhood shall be made where appropriate and required. All such pathways shall be accessible by the general public, except that walkways into and through the cottage development clusters may be limited to residents and their guests.
- K. Maintenance. The applicant shall demonstrate to the County, based upon review by the planning director, that there will be a suitable legally binding system in place, such as homeowner or condominium association agreements; conservation easement; deed restrictions; or an equivalent form, to ensure proper maintenance and funding of shared facilities, such as storm water facilities and detention ponds, shared parking areas, common open spaces, alleys and other improvements.
- L. Lighting. All developments shall comply with Section 5.6.1 (Outdoor lighting).
- M. For any provisions not captured in this section, then Sec. 5.7.5 shall apply.

\*\*\*

**Table 6.2: Off-street Parking Ratios**

Minimum and Maximum Parking Spaces		
Residential		
Use	Minimum Parking Spaces Required	Maximum Parking Spaces Allowed
Detached single-family dwelling	Two (2) spaces per dwelling unit.	Four (4) spaces per dwelling unit.
Single-Family cottage dwellings	One (1) space per dwelling unit, plus one-quarter (0.25) space per dwelling unit to accommodate guest parking.	Two (2) spaces per dwelling unit, plus one-quarter (0.25) space per dwelling unit to accommodate guest parking.

\*\*\*

**Sec. 9.1.3. Definitions.**

\*\*\*

*Dwelling unit, single-family, cottage:* a detached dwelling unit that is one (1) to two (2) stories (not to exceed twenty-two (22) feet) in height; no greater than 1,200 square feet; and arranged or clustered around a commonly shared open space.

*Productive Urban Landscape:* is a landscape that integrates some elements of traditional landscaping (like organized planting patterns and areas to sit, eat, and play), and creatively incorporates elements of the natural world (like biodiversity, pollinator habitats, etc.), and plants that provide us with food (like vegetables, berries, and fruit trees).

\*\*\*

**PART II. EFFECTIVE DATE**

This ordinance shall become effective immediately on the date of adoption by the board of commissioners and approval by the chief executive officer.

**PART III. SEVERABILITY**

Should any section or provision of this ordinance be declared by a court of competent jurisdiction to be invalid or unconstitutional, such decision shall not affect the validity of the ordinance as a whole nor any part thereof other than the part so declared to be invalid or unconstitutional. All ordinances or resolutions, or parts thereof, in conflict with this ordinance are repealed.

**ADOPTED** by the DeKalb County Board of Commissioners, this \_\_\_\_ day of \_\_\_\_\_, 2023.

---

**ROBERT J. PATRICK**  
Presiding Officer  
Board of Commissioners DeKalb County, Georgia

12/11/2023

**APPROVED** by the Chief Executive Officer of DeKalb County, this \_\_\_\_ day of \_\_\_\_\_, 2023.

\_\_\_\_\_  
**MICHAEL L. THURMOND**  
Chief Executive Officer  
DeKalb County, Georgia

**ATTEST:**

\_\_\_\_\_  
**BARBARA SANDERS-NORWOOD, CCC**  
Clerk to the Board of Commissioners and  
Chief Executive Officer  
DeKalb County, Georgia

**APPROVED AS TO FORM:**

**APPROVED AS TO SUBSTANCE:**

\_\_\_\_\_  
**VIVIANE H. ERNSTES**  
County Attorney

\_\_\_\_\_  
**CEDRIC G. HUDSON**  
Interim Planning & Sustainability Director

1. Perimeter Lot Compatibility—For a subdivision with 20 or more units, the *Zoning Code* requires that lots on the perimeter of the site must be at least 80% as wide and deep as adjacent abutting lots. Site plan does not indicate compliance.

Unit count has been reduced to (16) units.

2. Access Comments—Transportation Department reviewed and has the following comments: "Columbia Drive is classified as a minor arterial. Requires a 40-foot ROW dedication from centerline or such that all public infrastructure is within ROW, whichever greater. Requires a 10-foot shared path, 5-foot landscape strip between path and back of curb, and streetlights. Please note that private roads must be constructed to public road standards. They should be 24 feet wide instead of 20 feet wide. I am concerned that people will park along the road and not in the designated parking spots due to distance from spots to lots 2-9. Add no parking signs on both sides of the interior street from Columbia Drive to end of Lot 17. No parking allowed on Columbia Drive. Needs a spot for turnaround at the security gate if vehicles are not allowed to enter. They cannot back into Columbia Drive should entrance be denied."

- A 40' ROW dedication has been provided from the centerline of Columbia drive.
- A 10' sidewalk has been provided along Columbia Drive ROW
- The interior private road width has been increased in width to 24.'
- Developer will install no parking signs along interior road from security gate entrance to the end of the dumpster enclosure (NOTE: Conditions should be modified to include language restricting on-street parking in this location)
- Developer has revised entry drive to include a turnaround for vehicles denied entry to the community.

3. Internal Access—Private drives must provide a 10-foot-wide easement on both sides of the private drive, but this has not been provided. A 5-foot-wide sidewalk and a 5-foot-wide landscape strip is required along both sides of private drive.

- The Amended ordinance adopted 12/11/2023 does not require the 10' foot wide easement on both sides of the private drive.
- A 5' wide sidewalk and a 6' wide landscape has been provided at all locations along the private drive.

4. Parking Lot Perimeter Landscaping 5-foot-wide perimeter parking landscape strip is required but not provided.

- A 10-foot-wide perimeter parking landscape strip has been provided along all interior parking spaces.

5. A 6-foot-wide landscape strip is required along internal drives, and only a 5-foot-wide landscape strip is provided.

- A 6' wide landscape has been provided along the interior sidewalks along all interior drive.

6. Show compliance with front, side, and rear building setback requirements off proposed internal drive.
  - The amended ordinance adopted 12/11/2023 Section 27-5.7.9 D 2 exempts minimum lot width, setbacks and lot coverage.
7. Show compliance with front building setback requirements off Columbia Drive.
  - The amended ordinance adopted 12/11/2023 Section 27-5.7.9 D 2 exempts minimum lot width, setbacks, and lot coverage.
8. Cottage lot orientation—Lots 16 and 17 required to front along courtyard green
  - Lots 16 and 17 have been deleted.
9. Clarify amount of open space provided.
  - Open Space Required (Section 27-5.7.9 D 2) is 24,350
  - Open Space Provided is 27,316
10. Provide light poles along Columbia Drive for every 80 feet on center
  - Light poles have been provided along Columbia at 80' OC.
11. A ten-foot-wide no-access easement and 20-foot-wide landscape strip with decorative fence required along Columbia Drive frontage.
  - A 10' no access easement and 20' foot wide landscape easement has been provided along Columbia Drive
12. Need continuous internal sidewalk along north side of Lots 10-15 to provide a complete pedestrian circulation from any given unit.
  - Internal 5' sidewalk has been provided along lots 10-15.

(1) The location of the stormwater mgt facility (i.e., to address the requirements of sec.14.40, not just water quality) must be shown. Note: Stormwater mgt facility must be at least 20' from the property line.

- In accordance with The Amended ordinance adopted 12/11/2023 Section 27-5.7.5 O an Underground Detention facility will be located below the Enhanced Open Space and designed to also serve as a green space and include neighborhood amenities.

(2) The discharge location from the stormwater management facility must be shown. Notes: (1) discharge point must be at least 25' from the property line, (2) The stormwater mgt facility should not be discharged towards neighbors' house/backyards unless the proposed drainage system is extended through the downstream lots to an adequate outfall. Discharging the additional volume of runoff from the proposed development through downstream lots (no matter the discharge rate/how long it takes, that additional volume will be discharged), will adversely impact those downstream properties/lots. Compliance with Sec. 14-40(d)(1) ("A combination of storage and controlled release of stormwater runoff shall be required for all development and construction for the entire site which meets one (1) or more of the criteria in section 14-40(b)") must be addressed. (3) The County codes require the pre-development conditions to be modeled as wooded.

- Stormwater will be released on lot 1520 Columbia Circle parcel 15 186 04 006 as shown on revised site plan.

(3) Based on the current/existing topography, the site points to two receiving/study points (see screenshot below). However, on the proposed conceptual plan, there is only one location indicated as "water quality pond". If you will have one location of the stormwater mgt facility, you will need to explain/confirm: (1) that you will be changing the current drainage pattern by grading the site or designing your storm pipes network to achieve all runoff to be directed to the northeast corner so that no runoff is to be expected at the southeast corner in the post-development condition OR (2) how the stormwater management requirements will be addressed at the study point in the southeast corner considering all the proposed impervious compared to the pre-development conditions.

- See above stormwater release point, 1520 Columbia Circle

(4) Also, please indicate how RRV will be addressed. Runoff Reduction Volume shall be provided unless technical justification is provided regarding the unfeasibility. Strongly recommend investigating the site and identifying location where RRV can be provided, and redesigning/revising the layout to comply with the RRV requirement.

- RRV will be addressed by the installation of Flow-Well systems to all gutters and downspouts of each unit.

**Z-23-1246648 (2023-1143) – Deferral Request:**

**From:** Cecil Francis <[stixandstonesgeorgia@gmail.com](mailto:stixandstonesgeorgia@gmail.com)>  
**Sent:** Wednesday, October 18, 2023 11:53 AM  
**To:** Reid, John <[jreid@dekalbcountyga.gov](mailto:jreid@dekalbcountyga.gov)>  
**Subject:** Re: 1484 Columbia Dr

Yes. I will request a two-cycle deferral.

---

**From:** Reid, John <[jreid@dekalbcountyga.gov](mailto:jreid@dekalbcountyga.gov)>  
**Sent:** Wednesday, October 18, 2023 11:53 AM  
**To:** Cecil Francis <[stixandstonesgeorgia@gmail.com](mailto:stixandstonesgeorgia@gmail.com)>  
**Subject:** Re: renderings for 1484 Columbia Dr

Regarding deferral request, technically this item still has to be heard by the Planning Commission and Board of Commissioners since the item has already been legally advertised in newspaper. However, if you email me a request for deferral, Planning Department can recommend to the Planning Commission that this item be deferred for two cycles (they can't defer for less time than that due to public notification requirements) and most of the time the Planning Commission and Board of Commissioners will comply with the deferral request. Were you going to request deferral? I believe planning dept is leaning toward two or three-cycle deferral.

---

**From:** Cecil Francis <[stixandstonesgeorgia@gmail.com](mailto:stixandstonesgeorgia@gmail.com)>  
**Sent:** Thursday, October 12, 2023 8:59 PM  
**To:** Reid, John <[jreid@dekalbcountyga.gov](mailto:jreid@dekalbcountyga.gov)>  
**Subject:** Re: renderings for 1484 Columbia Dr

John:

After speaking with the Belvedere Park community, we are considering requesting a deferral of our presentation to the Planning Commission. Can you explain if that is possible at this stage of the process? The neighborhood has expressed an interest in hearing our proposal again and may recommend revisions to our request. Please advise.

Thanks



**DEKALB COUNTY  
GOVERNMENT PLANNING  
DEPARTMENT DISTRIBUTION  
FORM**

**NOTE: PLEASE RETURN ALL COMMENTS VIA EMAIL TO EXPEDITE THE PROCESS TO JOHN REID [jreid@dekalbcountyga.gov](mailto:jreid@dekalbcountyga.gov) AND/OR LASONDRA HILL [lahill@dekalbcountyga.gov](mailto:lahill@dekalbcountyga.gov)**

**COMMENTS FORM:  
PUBLIC WORKS TRAFFIC ENGINEERING**

Case No.: CZ-23-1246630 Parcel I.D. #: 15-186 <sup>07-028</sup>  
07-029  
 Address: 1784 + 1520 Columbia Drive Decatur, Ga. 30032

Adjacent Roadway (s):

(classification) (classification)

Capacity (TPD) \_\_\_\_\_  
 Latest Count (TPD) \_\_\_\_\_  
 Hourly Capacity (VPH) \_\_\_\_\_  
 Peak Hour Volume (VPH) \_\_\_\_\_  
 Existing number of traffic lanes \_\_\_\_\_  
 Existing right of way width \_\_\_\_\_  
 Proposed number of traffic lanes \_\_\_\_\_  
 Proposed right of way width \_\_\_\_\_

Capacity (TPD) \_\_\_\_\_  
 Latest Count (TPD) \_\_\_\_\_  
 Hourly Capacity (VPH) \_\_\_\_\_  
 Peak Hour Volume (VPH) \_\_\_\_\_  
 Existing number of traffic lanes \_\_\_\_\_  
 Existing right of way width \_\_\_\_\_  
 Proposed number of traffic lanes \_\_\_\_\_  
 Proposed right of way width \_\_\_\_\_

Please provide additional information relating to the following statement.

According to studies conducted by the Institute of Traffic Engineers (ITE) 6<sup>th</sup> Edition (whichever is applicable), churches generate an average of fifteen (15) vehicle trip end (VTE) per 1,000 square feet of floor area, with an eight (8%) percent peak hour factor. Based on the above formula, the \_\_\_\_\_ square foot place of worship building would generate \_\_\_\_\_ vehicle trip ends, with approximately \_\_\_\_\_ peak hour vehicle trip ends.

Single Family residence, on the other hand, would generate ten (10) VTE's per day per dwelling unit, with a ten (10%) percent peak hour factor. Based on the above referenced formula, the \_\_\_\_\_ (Single Family Residential) District designation which allows a maximum of \_\_\_\_\_ units per acres, and the given fact that the project site is approximately \_\_\_\_\_ acres in land area, \_\_\_\_\_ daily vehicle trip end, and \_\_\_\_\_ peak hour vehicle trip end would be generated with residential development of the parcel.

COMMENTS: No traffic engineering concerns at this time.

Signature: Jennifer Powell



10/16/2023

To: Mr. John Reid, Senior Planner  
From: Ryan Cira, Director, Division of Environmental Health  
Cc: Alan Gaines, Environmental Health Deputy Director  
Re: Rezone Application Review

General Comments:

DeKalb County Health Regulations prohibit use of on-site sewage disposal systems for

- multiple dwellings
- food service establishments
- hotels and motels
- commercial laundries
- funeral homes
- schools
- nursing care facilities
- personal care homes with more than six (6) clients
- child or adult day care facilities with more than six (6) clients
- residential facilities containing food service establishments

If proposal will use on-site sewage disposal, please contact the Land Use Section (404) 508-7900.

Any proposal which will alter wastewater flow to an on-site sewage disposal system, must be reviewed by this office prior to construction.

This office must approve any proposed food service operation or swimming pool prior to starting construction.

Public health recommends the inclusion of sidewalks to continue a preexisting sidewalk network or begin a new sidewalk network. Sidewalks can provide safe and convenient pedestrian access to a community-oriented facility and access to adjacent facilities and neighborhoods.

For a public transportation route, there shall be a 5ft. sidewalk with a buffer between the sidewalk and the road. There shall be enough space next to the sidewalk for bus shelter's concrete pad installation.

Since DeKalb County is classified as a Zone 1 radon county, this office recommends the use of radon resistant construction.

N1-2023-1142

CZ-23-1246630 / 15-186-04-029

1484 and 1520 Columbia Drive, Decatur, GA 30032

- See review general comments.
- Septic indicated on several surrounding properties.

N2-2023-1143

Z-23-1246648 /15-163-01-008

4822 Covington Hwy, Decatur, GA 30035

- Please review general comments.

N3-2023-1146

SLUP-23-1246650 / 18-062--03-001

1726 Church Street, Decatur, GA 30033

- Please review general comments.
- Septic indicated on surrounding properties.

N4-2023-1147

Z-23-1246652 / 16-193-04-004, 16-193-04-005

8070 and 8080 Rockbridge Road, Stone Mountain, GA 30087

- Septic 1000 gallons indicated on 8070 Rockbridge Road, installed on 03/17/1981.
- Please review general comments.

## OCTOBER 2023 ZONING COMMENTS

- 1. N-1. 1484 and 1520 Columbia Drive.** Columbia Drive is classified as a minor arterial. Requires a 40-foot ROW dedication from centerline or such that all public infrastructure is within ROW, whichever greater. Requires a 10-foot shared path, 5-foot landscape strip between path and back of curb, and streetlights required. Please note that private roads must be constructed to public road standards. They should be 24 feet wide instead of 20 feet wide. I am concerned that people will park along the road and not in the designated parking spots due to distance from spots to lots 2-9. Add no Parking signs on both sides of the interior street from Columbia Drive to end of Lot 17. No parking allowed on Columbia Drive. Needs a spot for turnaround at the security gate if vehicles are not allowed to enter. They cannot back into Columbia Drive should entrance be denied.
- 2. N-2 4822 Covington Hwy.** Covington Hwy is SR 12. GDOT review and permits required. Covington Hwy is classified as a major arterial. ROW dedication of 50 feet from center line or such that all public infrastructure is within ROW, whichever greater. Requires a 10-foot shared path, 5-foot landscape strip between back of curb and path, streetlights required. Required to upgrade traffic signal to provide pedestrian facilities. GDOT signal permit required.
- 3. N-3. 1726 Church St.** Scott Blvd is SR 8 and requires GDOT review and approval prior to permitting. Scott Blvd is classified as a major arterial. Requires: Requires a 50-foot ROW dedication from centerline or such that all public infrastructure is within ROW, whichever greater. A 10-foot shared path, 5-foot landscape strip between back of curb and path, streetlights required. No access allowed directly to Scott Blvd. Church Street is classified at a minor arterial. Requires a 40-foot ROW dedication from centerline or such that all public infrastructure is within ROW, whichever greater. A 10-foot shared path, 5-foot landscape strip between back of curb and path, streetlights required. One right in right out access only along Church Street- prefer no access. Connector street is classified as local. Requires a 27.5-foot ROW dedication from centerline or such that all public infrastructure is within ROW, whichever greater. Requires 5-foot landscape strip between back of curb and sidewalk, 6-foot sidewalk, streetlights required.
- 4. N-4 & N-5 8070 and 8080 Rockbridge Rd.** Rockbridge Road is SR 124. GDOT review and permitting required. Rockbridge Rd is classified as a major arterial. Requires: Requires a 50-foot ROW dedication from centerline or such that all public infrastructure is within ROW, whichever greater. A 10-foot shared use path, 5-foot landscape strip between back of curb and path, streetlights required. Design entrance as a typical right in/right out for driver clarity. South Rockbridge Road is a minor arterial. Requires a 40-foot ROW dedication from centerline or such that all public infrastructure is within ROW, whichever greater. A 10-foot shared path, 5-foot landscape strip between back of curb and path, streetlights required.
- 5. N-6. 2179 Bouldercrest Rd.** Bouldercrest Rd is a classified as a major arterial. Requires a 50-foot ROW dedication from centerline or such that all public infrastructure is within ROW, whichever greater. Requires a 10-foot shared path, add curb and gutter, 5-foot landscape strip between back of curb and path, and streetlights. Verify that each driveway meets minimum intersection and stopping sight distance per AASHTO.
- 6. N-7. 1716 Pleasant Hill Trails and Various Pleasant Hill Road Major Mod** Pleasant Hill Trail is a local road and must be improved as part of this development's frontage. Requires a 27.5-foot ROW dedication from centerline or such that all public infrastructure is within ROW, whichever greater. From the centerline- the road must be improved to be 12 feet wide with curb and gutter, 5-foot landscape strip and a 5-foot sidewalk, streetlights required. Pleasant Hill Road is classified as a minor arterial. Requires a 40-foot ROW dedication

from centerline or such that all public infrastructure is within ROW, whichever greater. From the centerline- the road must be improved to be 12 feet wide with curb and gutter, 10-foot shared path, 5-foot landscape strip between path and back of curb, streetlights required. Both access points must meet minimum sight distance requirements per AASHTO for intersection and stopping sight distance. Pleasant Hill Road has a speed limit of 45 mph. A variance is needed for minimum number of access points per section 14-200 (5) of the land development code. For the Transportation Division to support the variance, a full intersection design with left turn lanes and right turn lanes will be required at Providence Point Dr and the new road. Consider adding traffic calming measures on interior streets to determine driveway placement. (Hard to retrofit townhome communities with traffic calming.) Assuming interior streets will be private based on plan provided. Private streets must be built to public road standards.

7. **N-8. & N-9. 2536 Snapfinger Rd.** I-20 Overlay District Tier 3. Overlay standards take precedent- where silent the zoning and then the land development standards are applied. Snapfinger Road is classified as a major arterial. ROW dedication of 50 feet from center line of Snapfinger Rd or such that all public infrastructure is within ROW, whichever greater. Follow the infrastructure requirements of the overlay district, but at a minimum: The public roads to the east and north require a right of way dedication of 27.5 feet from centerline, five-foot landscape strip from back of curb, 5-foot sidewalk and street lighting.
8. **N-10. 2569 & 73 Dusty Lane.** Dusty Lane is classified as a local road. Required to dedicate 27.5 feet of right of way from centerline or such that all public infrastructure is within right of way, whichever greater. Requires five-foot landscape strip from back of curb to sidewalk, five-foot sidewalk and pedestrian lighting.
9. **N-11 & N-12. 3823 N Druid SLUP.** Eliminate one curb cut on North Druid Hills Rd. North Druid Hills Rd is classified as a major arterial. ROW dedication of 50 feet from center line or such that all public infrastructure is within ROW, whichever greater. Requires a 10-foot shared path, 5-foot landscape strip between back of curb and path, streetlights required. Provide necessary driveway easements/ROW for the Birch Road at North Druid Hills Rd Intersection project. Coordinate with PW- Transportation on easement/ROW.
10. **N-13. 4381 Covington Hwy.** Covington Hwy is SR 12. GDOT review and permits required. Covington Hwy is classified as a major arterial. ROW dedication of 50 feet from center line or such that all public infrastructure is within ROW, whichever greater. Requires a 10-foot shared path, 5-foot landscape strip between back of curb and path, streetlights required.
11. **N-14.** No Comment.

**DeKalb County School District  
Development Review Comments**

Analysis Date: 10/15/2014

Submitted to: D... ..

Case #: 14...

Parcel #: 14...

Name of Development: 14... Dr  
Location: ... Dr, ...

Description: Residential development...

Impact of Development: ...

Current Condition of Schools	Peachcrest Elementary School	Bethune Middle School	Towers High School	Other DCSD Schools	Private Schools	Total
...	4	1,000	1,000			
...						
...		74	77			
...			4			
...		4	1			

New students from development: 1, 0, 0, 0, 0, 0

...	74	77	
...		4	
...	7	4	1

Yield Rates	Attend Home School	Attend other DCSD School	Private School	Total
...	0.017		0.017	0.034
...		0.01		0.01
...	0.017		0.04	0.057
<b>Total</b>	<b>0.0294</b>	<b>0.1006</b>	<b>0.0167</b>	<b>0.1467</b>
<b>Student Calculations</b>				
Proposed Units	...			
Unit Type	SF			
Cluster	...			
Units x Yield	Attend Home School	Attend other DCSD School	Private School	Total
...		1		1
...		4		4
...		4		4
<b>Total</b>	<b>0.58</b>	<b>2.00</b>	<b>0.33</b>	<b>2.91</b>
Anticipated Students	Attend Home School	Attend other DCSD School	Private School	Total
...	1	1		2
...				
...		1		1
<b>Total</b>	<b>1</b>	<b>2</b>	<b>0</b>	<b>3</b>





## DEKALB COUNTY GOVERNMENT PLANNING DEPARTMENT DISTRIBUTION FORM

**NOTE: PLEASE RETURN ALL COMMENTS VIA EMAIL TO EXPEDITE THE PROCESS TO JOHN REID [jreid@dekalbcountyga.gov](mailto:jreid@dekalbcountyga.gov) AND/OR LASONDRA HILL [lahill@dekalbcountyga.gov](mailto:lahill@dekalbcountyga.gov)**

Recommend denial

---

The following areas below may warrant comments from the Development Division. Please respond accordingly as the issues relate to the proposed request and the site plan enclosed as it relates to Chapter 14. You may address applicable disciplines.

### DEVELOPMENT ANALYSIS:

- **Transportation/Access/Row**

---

- (1) The internal street(s) must be at least 24' for the travel lanes (2 x 12') and have a R/W of 55
- (2) 12 units/lots do not have garage; therefore at least 12 x 2 = 24 parking spaces are required. Concept plan only shows 19. Also, parking spaces shall be close to units/lots. It doesn't make sense to expect owner of lots 1 thru 9 and 19, 20 to park where the spaces in the northwest corners are

- **Storm Water Management**

- (1) the location of the stormwater mgt facility (i.e. to address the requirements of sec.14.40, not just water quality) must be shown. Note: Stormwater mgt facility must be at least 20' from the property line
- (2) The discharge location from the stormwater management facility must be shown. Notes: (1) discharge point must be at least 25' from the property line, (2) the stormwater mgt facility should not be discharged towards neighbors' house/backyards unless the proposed drainage system is extended through the downstream lots to an adequate outfall. Discharging the additional volume of runoff from the proposed development through downstream lots (no matter the discharge rate/how long it takes, that additional volume will be discharged), will adversely impact those downstream properties/lots. Compliance with Sec. 14-40(d)(1) ("A combination of storage and controlled release of stormwater runoff shall be required for all development and construction for the entire site which meets one (1) or more of the criteria in [section 14-40\(b\)](#)") must be addressed. (3) The County codes require the pre-development conditions to be modeled as wooded.
- (3) Based on the current/existing topography, the site points to two receiving/study points (see the screenshot below). However, on the proposed conceptual plan, there is only one location indicated as "water quality pond". If you will have one location of the stormwater mgt facility, you will need to explain/confirm: (1) that you will be changing the current drainage pattern by grading the site or designing your storm pipes network to achieve all runoff to be directed to the northeast corner, so that no runoff is to be expected at the southeast corner in the post-development condition OR (2) how the stormwater management requirements will be addressed at the study point in the southeast corner considering all the proposed impervious compared to the pre-development conditions.
- (4) Also, please indicate how RRv will be addressed. Runoff Reduction Volume shall be provided unless technical justification is provided regarding the unfeasibility. Strongly recommend investigating the site and identifying location where RRv can be provided, and re-designing/revising the layout to comply with the RRv requirement.

- **Flood Hazard Area/Wetlands**

The presence of FEMA Flood Hazard Area was not in the County G.I.S. mapping records for the site; and should be noted in the plans at the time of any land development permit application.

Encroachment of flood hazard areas require compliance with Article IV of Chapter 14 and FEMA floodplain regulations

- **Landscaping/Tree Preservation**

Landscaping and tree preservation plans for any building, or parking lot must comply with DeKalb County Code of Ordinances 14-39 as well as Chapter 27 Article 5 and are subject to approval from the County Arborist.

- **Tributary Buffer**

State water buffer was not reflected in the G.I.S. records for the site. Typical state waters buffer have a 75' undisturbed stream buffer and land development within the undisturbed creek buffer is prohibited without a variance per DeKalb County Code of Ordinances 14-44.1.

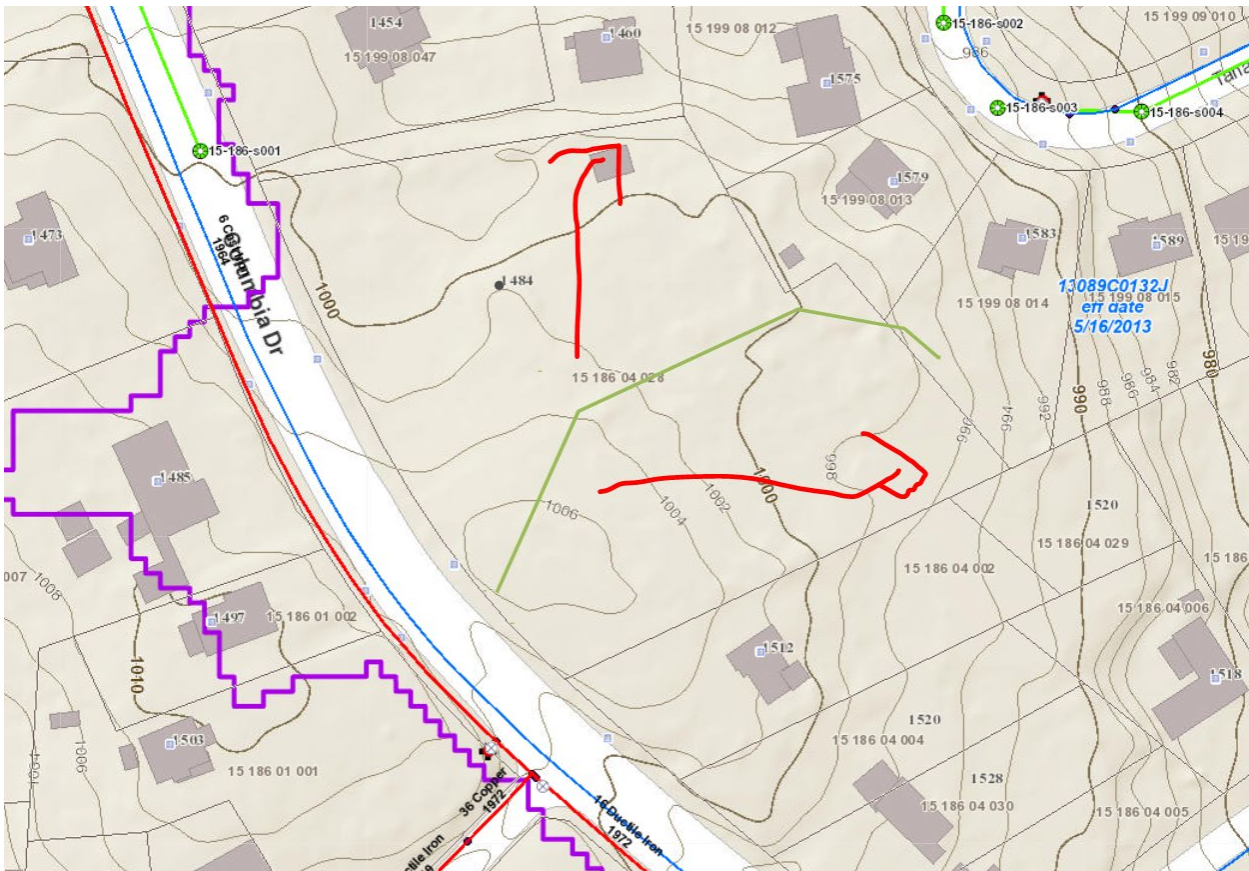



**DEKALB COUNTY GOVERNMENT  
PLANNING DEPARTMENT  
DISTRIBUTION FORM**

**NOTE: PLEASE RETURN ALL COMMENTS VIA EMAIL OR FAX TO EXPEDITE THE PROCESS TO JOHN REID [jreid@dekalbcountyga.gov](mailto:jreid@dekalbcountyga.gov) AND/OR LASONDRA HILL [lahill@dekalbcountyga.gov](mailto:lahill@dekalbcountyga.gov)**

**REZONE  
COMMENTS FORM:  
PUBLIC WORKS ROAD AND DRAINAGE**

**Case No.:** CZ-23-1246630

**Parcel I.D. #:** 15-186-04-028 and 15-186-04-004

**Address:** 1484 & 1520 Columbia Drive, GA 30032

**Drainage Basin:** Cobb Creek

**Upstream Drainage Area:** N/A

**Percent of Property in 100-Year Floodplain:** 0%

**Impact on property (flood, erosion, sedimentation) under existing zoning:** Flood impact on this property is expected to be minimal since it is in zone X which is outside the floodplain and otherwise referred to as Special Flood Hazard Area. Erosion and sedimentation is also not expected to be prevalent due to the topographic gradient on of the property.

---

**Required detention facility(s):** Detention/retention facilities would be required for stormwater management per section 14-40 and other relevant code sections of DeKalb County codes of ordinance as applicable.

---

**COMMENTS:**

No objection to modification to the zoning conditions as applicant has requested. A total compliance with the relevant sections of the County code of ordinance relating to erosion, sedimentation and pollution control is required. Also, Sec. 14-40 and 14-42 must be complied with.

**Signature:** \_\_\_\_\_



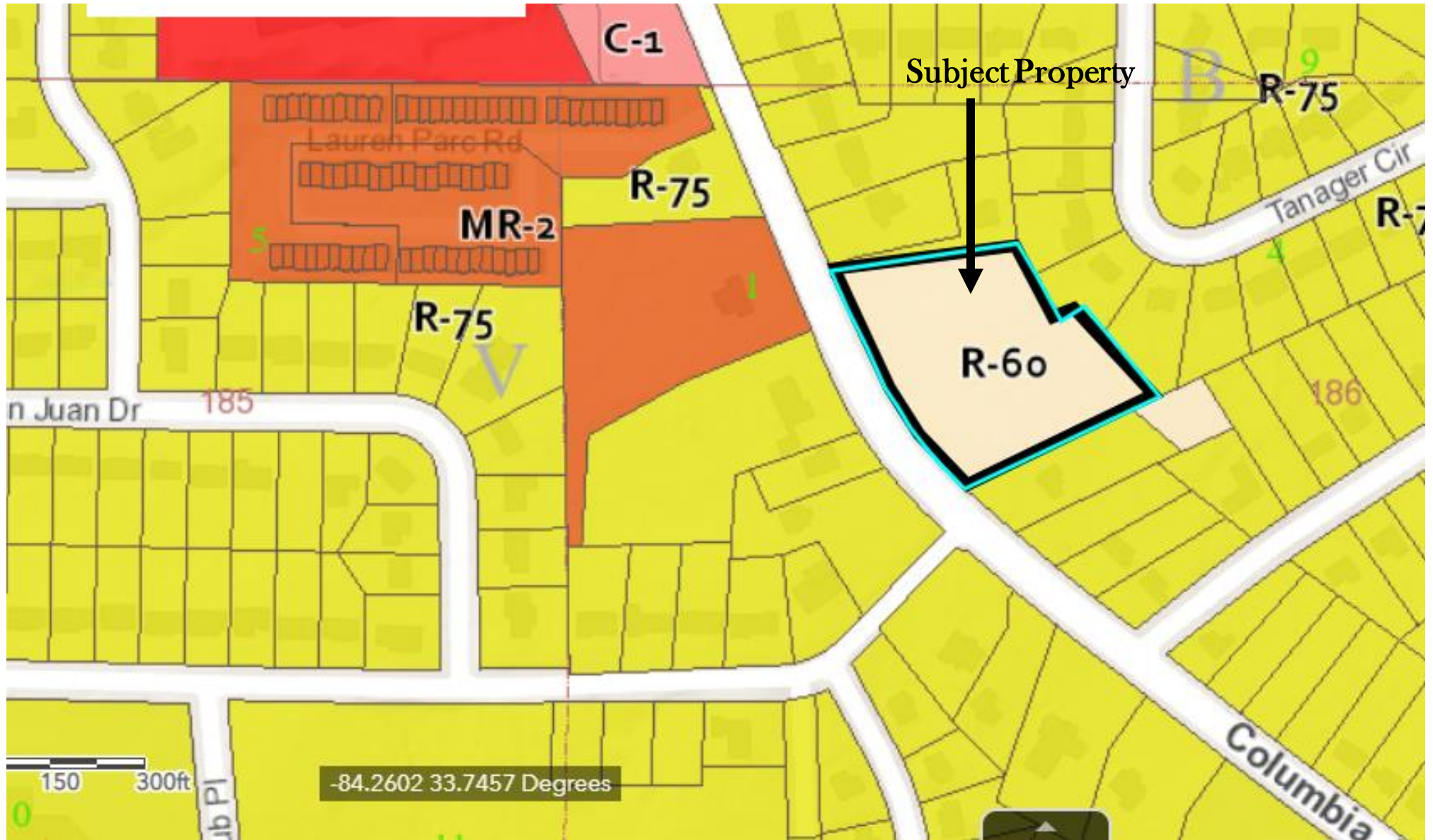

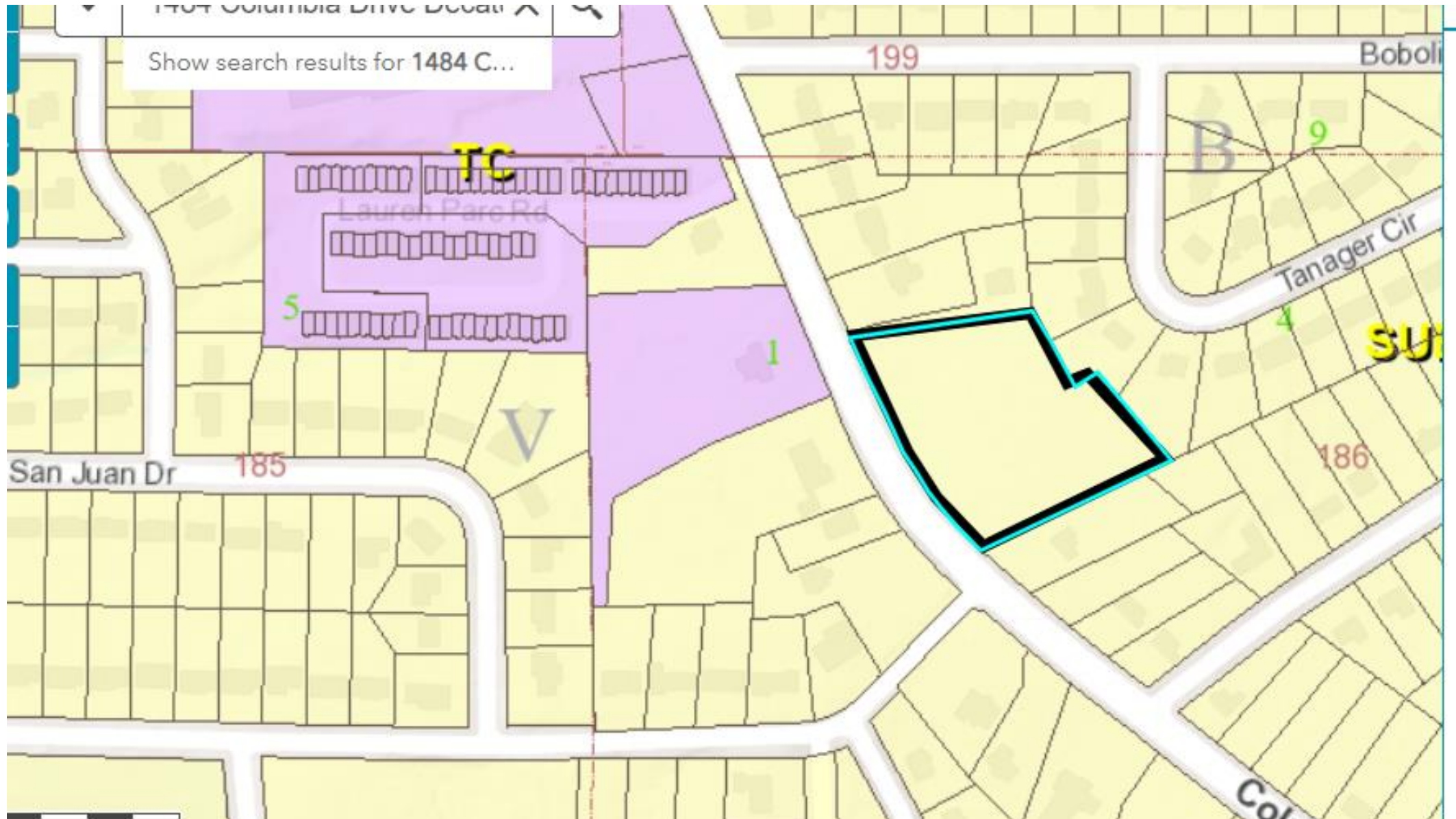

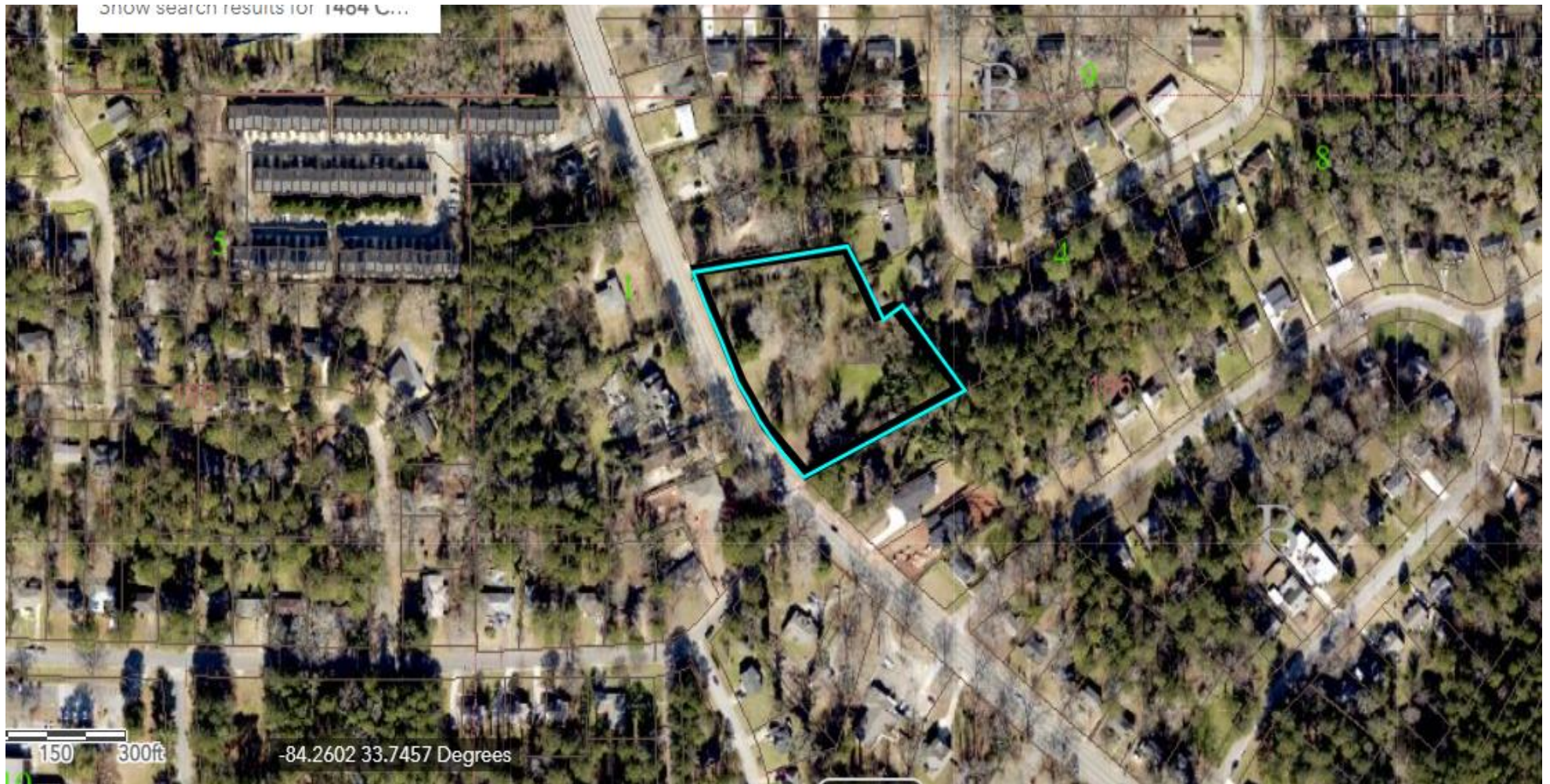



404.371.2155 (o)  
404.371.4556 (f)  
DeKalbCountyGa.gov

Clark Harrison Building  
330 W. Ponce de Leon Ave  
Decatur, GA 30030

DEPARTMENT OF PLANNING & SUSTAINABILITY

MAJOR MODIFICATION APPLICATION

Existing Conditional Zoning No.: 1245596

APPLICANT NAME: Stix & Stones Homes, LLC

Daytime Phone#: 404-454-6699 Fax #: 678-922-7333 E-mail: stixandstonesgeorgia@gmail.com

Mailing Address: PO Box 4359 Atlanta GA 30302

OWNER NAME: Kova Real Estate, LLC (If more than one owner, attach contact information for each owner)

Daytime Phone#: 678-598-1964 Fax #: \_\_\_\_\_ E-mail: contactchima@gmail.com

Mailing Address: 3321 Mallard Lake Place Alpharetta GA 30022

SUBJECT PROPERTY ADDRESS OR LOCATION: 1484 Columbia Drive and 1520 Columbia Drive

Decatur GA, DeKalb County, GA, 30032

District(s): 15 Land Lot(s): 186 Block(s): \_\_\_\_\_ Parcel(s): 15-186-04-028 and 15-186-04-029

Acreage or Square Feet: 2.795 Commission District(s): 3 Existing Zoning: R60

I hereby authorize the staff of the Planning and Development Department to inspect the property that is the subject of this application.

Have you, the applicant, made a campaign contribution of \$250.00 or more to a DeKalb County government official within the two year period that precedes the date on which you are filing this application?

\_\_\_\_\_ Yes  No If "yes", see page 4. (Conflict of Interest in Zoning Act, O.C.G.A., Chapter 36-67A)

Owner: \_\_\_\_\_ Agent:  (Check One)

Signature of Applicant: Cecil Francis

Printed Name of Applicant: Stix & Stones Homes, LLC Major Modification Application

**PRE-APPLICATION FORM**  
**REZONE, SPECIAL LAND USE PERMIT, MODIFICATION, AND LAND USE**  
**(Required prior to filing application: signed copy of this form must be submitted at filing)**

Applicant Name:  Cecil Francis  Phone:  404-454-6699  Email:

Property Address:  1484 Columbia Drive

Tax Parcel ID:  15 186 04 028 & 029  Comm. District(s):  3 & 7  Acreage:  2.7 acres

Existing Use:  Vacant land

Supplemental Regs:  NA  Overlay District:   DRI:  NA

**Rezoning:** Yes   No  X

Existing Zoning:  R-60 with zoning conditions per case Z-22 1245596  Proposed Zoning:  NA

Rezoning Request:  
\_\_\_\_\_

**Land Use Plan Amendment:** Yes   No  X

Existing Land Use:  Suburban (SUB)  Proposed Land Use:  NA  Consistent    
Inconsistent

**Special Land Use Permit:** Yes   No  X  Article Number(s) 27-\_\_\_\_\_

**Major Modification:**

Existing Case Number(s):  Y

Condition(s) to be modified:

R-60 with zoning conditions per case 1245596 --major modification to condition #1 to increase the number of units from 11 to 20 units and change the land use from single-family conventional to single-family cottage at a density of 7.3 units per acre





DEPARTMENT OF PLANNING & SUSTAINABILITY

This document is a preliminary review of the rezoning application and is not a complete list of zoning requirements, a final and complete review will be done upon official submission of a rezoning application and concept plan.

**This only a preliminary review and is not a complete list of zoning requirements, a final and complete review will be done upon official submission of a rezoning application and concept plan.**

Planner: John Reid Date 07/11/23

Filing Fees

<b>REZONING:</b>	RE, RLG, R-100, R-85, R-75, R-60, MHP, RSM, MR-1	\$500.00
	RNC, MR-2, HR-1, HR-2, HR-3, MU-1, MU-2, MU-3, MU-4, MU-5	\$750.00
	OI, OD, OIT, NS, C1, C2, M, M2	\$750.00
<b>LAND USE MAP AMENDMENT</b>		\$500.00
<b>SPECIAL LAND USE PERMIT</b>		\$400.00

# **PUBLIC PARTICIPATION LETTER**





Stix &  
Stones

July 27, 2023

Re: petitioner Stix & Stones Homes, LLC (Cecil Francis)

Subject: Community Meeting Notice, Major Modifications to Zoning Conditions

Dear Neighbor,

You are receiving this notice because you own property within 500 feet of 1484 Columbia Drive (the "Subject Property"). The petitioner is seeking a Major Modification to Zoning Conditions for the construction of 20 cottage style homes.

You are invited to participate in a virtual Community Meeting on Monday August 14, 2023 at 6:00 PM.

Cecil Francis is inviting you to a scheduled Zoom meeting.

Join Zoom Meeting

<https://us06web.zoom.us/j/83202156299?pwd=ME9kWnNLTG0rL0pyWkF6UVRIZkQ2dz09>

**Meeting ID: 832 0215 6299**

**Passcode: 008137**

**This application will be presented at the DeKalb County Planning Commission meeting on 11/02/2023 and the Board of Commissioners meeting on November 16, 2023.**

**Should you have any questions regarding this application, please feel free to contact Cecil Francis at (404) 454-6699.**

1484 COLUMBIA DRIVE  
PRE-APPLICATION MEETING  
08/14/2023

### Meeting Participants

Export with meeting data

Report to Zoom

Name (Original Name)	User Email	Join Time	Leave Time	Duration (Minutes)	Guest	Recording Consent	In Waiting Room
17702941657		08/14/2023 05:53:13 PM	08/14/2023 06:24:46 PM	32	Yes		No
Cecil Francis	stixandstoneageorgia@g...	08/14/2023 05:54:03 PM	08/14/2023 06:24:46 PM	31	No		No
Candis Conley# REALTO...		08/14/2023 05:58:51 PM	08/14/2023 06:24:45 PM	26	Yes	Yes	No
JordacheAvery		08/14/2023 06:00:33 PM	08/14/2023 06:24:45 PM	25	Yes	Yes	No
VALRIE KONG-QUEE		08/14/2023 06:03:19 PM	08/14/2023 06:24:47 PM	22	Yes	Yes	No



DOUGHERTY THOMAS R  
3098 LAUREN PARC RD  
DECATUR, GA 30032

FARLEY ROSA M  
3199 BOBOLINK DRIVE  
DECATUR, GA 30032

THOMAS HORACE  
3142 BOBOLINK DRIVE  
DECATUR, GA 30032

LOPEZ SARAH M  
2988 LAUREN PARC RD  
DECATUR, GA 30032

CALKINS JOE  
3106 SAN JUAN DRIVE  
DECATUR, GA 30032

SFR ATL OWNERS 3 LP  
4645 HAWTHORNE LANE  
WASHINGTON DC 20016

RAILEY AUGUSTUS WALTER JR  
1463 COLUMBIA DRIVE  
DECATUR, GA 30032

J AND E EFFICIENCY HOMES LLC  
1485 S INDIAN CREEK DRIVE  
STONE MOUNTAIN, GA 30083

HUGHES ANDERSON  
2205 BONNETT CT  
ATLANTA GA 30345

RAMOS SASHA  
1643 GUY WAY  
DECATUR, GA 30032

LEONG ERICA CHAE  
PO BOX 586  
AVONDALE ESTATES, GA 30002

JONES DIANE R  
3982 ROLLING PLACE  
CONLEY GA 30288

CHEVER GLORIA J  
2573 BRITTANY PARK LANE  
ELLENWOOD, GA 30294

KERR MORRIS  
1532 COLUMBIA CIRCLE  
DECATUR, GA 30032

SIMSBERRY CONSTRUCTION LLC  
4545 S BERKELEY LAKE ROAD  
NORCROSS, GA 30071

WILLIAMS MARLENE A  
1642 IVY GLENN ROAD  
DECATUR, GA 30032

SCHUMAKER JEANNE M  
2667 E MCKINNON DRIVE  
DECATUR GA 30030

NEW ACE PROPERTIES LLC  
2079 SUGAR SPRINGS DRIVE  
LAWRENCEVILLE, GA 30043

LWSW LIMITED PARTNERSHIP  
3328 SILVER SPUR CT  
THOUSAND OAKS, CA 91360

THE CHRISTIAN JUBILEE  
PO BOX 1576  
DECATUR, GA 30031

MSEZANE ALFRED Z  
2470 ALSTON DRIVE SE  
ATLANTA, GA 30317

COLEMAN GROUP ENTERPRISES LLC  
2465 ODELL WAY  
ATLANTA GA 30337

LAU PAUL  
4827 GATHERING PLACE  
SUWANEE GA 30024

GOODMAN LAQUETA W  
12 KINGSTONE ROAD  
AVONDALE ESTATE GA 30002

VILLALONA MONIQUE LISANGIE  
3167 BOBOLINK DRIVE  
DECATUR, GA 30032

WATSON BETHANY M  
1539 COLUMBIA CIRCLE  
DECATUR, GA 30032

EARL WILLIAM JR  
1742 PARKHILL DRIVE  
DECATUR, GA 30032

BROCKTON PARTNERS LLC  
315 W PONCE DE LEON AVENUE  
STE 700  
DECATUR, GA 30030

SAMUELS ROOSEVELT  
3148 BOBOLINK DRIVE  
DECATUR, GA 30032

TRUST JVCL  
3745 PREAKNESS DRIVE  
DECATUR GA 30034

SCOTT ROSALYN  
1460 COLUMBIA DRIVE  
DECATUR, GA 30032

AUGUSTE KHADEJAH  
1548 COLUMBIA DRIVE  
DECATUR, GA 30032

BASS THOMAS  
2990 LAUREN PARC ROAD  
DECATUR, GA 30032

JENKINS SYLVIA  
3112 BRIANS CREEK DRIVE SE  
CONYERS GA 30013

MCCOY STEPHANIE R  
1560 COLUMBIA DRIVE  
DECATUR, GA 30032

SCOTT LAUREN P  
3144 SANTA MONICA DRIVE  
DECATUR GA 30032

HESS RETAIL STORES LLC  
539 S MAIN STREET  
FINDLAY OH 45840

STEPHENSON ALEXANDRIA R  
1545 COLUMBIA DRIVE  
DECATUR, GA 30032

KHA THANH HONG THI  
5319 GALLEON XING  
DECATUR, GA 30035

MAJOR GENA  
3092 LAUREN PARC ROAD  
DECATUR, GA 30030

JAMESON TONY M JR  
1567 TANAGER CIRCLE  
DECATUR, GA 30032

MUSSINGTON SHAKIYA R  
3446 WICKHAM AVENUE  
BRONX NY 10469

RYAN CHANEL N  
3088 LAUREN PARC ROAD  
DECATUR GA 30030

BEALL CUYLER E  
1575 TANAGER CIRCLE  
DECATUR, GA 30032

WINDSOR DEVELOPMENT GROUP, LLC  
4565 MILLENIUM VIEW COURT  
SNELLVILLE GA 30039

JOHNSON G ARLENE  
3118 SANTA MONICA DRIVE  
DECATUR GA 30032

LOMAX JESSICA  
1609 TANAGER CIRCLE  
DECATUR, GA 30032

D MAGEN LLC  
PO BOX 386  
MARIETTA GA 30061

CACEDA RICARDO  
38 RIVER RIDGE CIRCLE  
LITTLE ROCK AR 72227

FIELDS WILLIE JOYCE  
1600 TANAGER CIRCLE  
DECATUR, GA 30032

ALLIANCE BUILDING CONTRACTORS LLC  
3480 PARK DRIVE  
SNELLVILLE GA 30039

FYR SFR BORROWER LLC  
3505 KOGER BLVD STE 400  
DULUTH GA 30096

LI LI  
620 NEWPORT SHR  
ALPHARETTA GA 30005

SUNDSTORM CHLOE REBECCA  
3207 BOBOLINK DRIVE  
DECATUR GA 30032

UNITY REALTY COMPANY INC  
5805 GROVE PLACE XING  
LILBURN GA 30047

CROMER LA CHENNA  
18055 CARDONI STREET  
DETROIT MI 48203

MARSHALL FLOYD  
1612 TANAGER CIRCLE  
DECATUR GA 30032

ROBBINS JOHN ALAN  
1548 COLUMBIA CIRCLE  
DECATUR, GA 30032

BROWN TAMARA K SUTTON  
3096 LAUREN PARC RD #3  
DECATUR, GA 30032

ASHER ABRAHAM  
1306 BREEZY LANE NE  
ATLANTA GA 30329

OPENDOOR PROPERTY J LLC  
410 N SCOTTSDALE ROAD STE 1600  
TEMPE AZ 85281

ANDERSON VALERIE  
1579 TANAGER CIRCLE  
DECATUR GA 30032

MARKHAM JONATHAN  
1163 SPRINGDALE ROAD  
ATLANTA GA 30306

SIMSBERRY CONSTRUCTION LLC  
PO BOX 920790  
NORCROSS GA 30010

AGIP LLC  
1373 DUPONT COMMONS CIRCLE  
ATLANTA GA 30318

GENE BROWN S  
2665 DRIVE BRAMLETT ROAD  
CUMMING GA 30028

HALL GREGORY WAYNE  
3191 BOBOLINK DRIVE  
DECATUR, GA 30032

CHAUNDRY MIKHAIL  
1533 COLUMBIA CIRCLE  
DECATUR, GA 30032

NUTHMAN PROPERTIES LLC  
3201 ESPERANZA XING APT 228  
AUSTIN TX 78758

DURDIN JOAN BURKE  
1592 TANAGER CIRCLE  
DECATUR, GA 30032

TUTTLE EARL J JR  
2667 E MCKINNIN DRIVE  
DECATUR, GA 30030

FREEMPORT TITLE AND GUARANTY  
PO BOX 206  
SCOTTSDALE GA 30079

FRYE IAN MILLOY  
3102 SAN JUAN DRIVE  
DECATUR, GA 30032

SPEAKS DENISE D  
PO BOX 628  
AVONDALE ESTATES GA 30002

CURRY WARREN R  
1554 COLUMBIA DRIVE  
DECATUR, GA 30032

GORDON ROBERT  
3084 LAUREN PARC ROAD  
DECATUR, GA 30032

WILLIAMS CHINETTE D  
3152 BOBOLINK DRIVE  
DECATUR, GA 30032

GUY FAMILY LLC  
901 NE ADAIR AVENUE  
ATLANTA GA 30306

LOUIS CHARLES KIMBERLY  
3082 LAUREN PARC  
DECATUR GA 30032

STAR 2021 SFR1 BORROWER LP  
591 W PUTNAM AVENUE  
GREENWICH CT 06830

DEVELOPING MINDS INC  
2911 LOCH LOMOND DRIVE  
CONYERS GA 30094

HUMANSKI JESSICA M  
1497 COLUMBIA DRIVE  
DECATUR GA 30032

HUGHES ANDERSON  
2205 BONNEVIT COURT  
ATLANTA GA 30345

SMITH ROSITA  
3174 BOBOLINK DRIVE  
DECTAUR, GA 30032

PETTIFORD LAURA E  
5277 ROSSER ROAD  
STONE MOUNTAIN GA 30087

WOLFF ANDREA  
2888 DAWS AVE SE  
ATLANTA GA 30317

BAKER MARY L  
1438 COLUMBIA DRIVE  
DECATUR, GA 30032

BUMGARDNER MARK  
PO BOX 2175  
DECATUR GA 30031

NIYIBIZI NYIRAMUGISHA K  
1562 TANAGER CIRCLE  
DECATUR GA 30032

EK REAL ESTATE FUND I LLC  
215 PARK AVENUE S STE 1713  
NEW YORK NY 10003

WINES BOBBY J JR  
3149 BOBOLINK DRIVE  
DECATUR, GA 30032

ADEFILA MOROMOKE  
3086 LAUREN PARC ROAD  
DECATUR, GA 30032

REAGIN ROBERT W  
1571 TANAGER CIRCLE  
DECATUR GA 30032

BROWN JORDYN  
2986 LAUREN PARC ROAD  
DECTAUR, GA 30032

KELLY CAROLYN A  
2950 SANDY CIRCLE  
DECATUR GA 30296

BRYANT SHARON E  
3138 SANTAMONICA DRIVE  
DECATUR GA 30032

CLEMENTS LEAH  
1448 COLUMBIA DRIVE  
DECATUR GA 30032

JACKSON BRITTNEY  
1518 COLUMBIA CIRCLE  
DECATUR GA 30032

SFR XII OWNER 1 LP  
4645 HAWTHORNE WAY  
WASHINGTON DC 20016

JEWEL BOX DEVELOPMENT PARTNERS  
LLC  
3279 PINEHILL DRIVE  
DECATUR GA 30032

SFR ATL OWNER 2 LP  
4645 HAWTHORNE LANE  
WASHINGTON DC 20016

ANDREWS ANGELA  
PO BOX 2246  
DECATUR GA 30081

TAYLOR PERSITA  
1647 IVY GLENN ROAD  
DECATUR GA 30032

EVERHART HENRY  
3164 BOBOLINK DRIVE  
DECATUR, GA 30032

### Community Council Board -- District 3

Elfreda Berry	<a href="mailto:elfreda227@att.net">elfreda227@att.net</a>
Pat Craig	<a href="mailto:pat.lawrencecraig@gmail.com">pat.lawrencecraig@gmail.com</a>
Peggy Hobdy	<a href="mailto:phtompson3@msn.com">phtompson3@msn.com</a>
Netti Jackson	<a href="mailto:NettieJackson@me.com">NettieJackson@me.com</a>
Carolyn Jones	<a href="mailto:carolyn.jones818@yahoo.com">carolyn.jones818@yahoo.com</a>
Robert Murphy	<a href="mailto:rmurphyga@gmail.com">rmurphyga@gmail.com</a>
Kenneth Wayne Powell	<a href="mailto:pdk-powell@comcast.net">pdk-powell@comcast.net</a>
Willie Pringle	<a href="mailto:tolip209@gmail.com">tolip209@gmail.com</a>
Regenia Roberts	<a href="mailto:regeniarobertsone@gmail.com">regeniarobertsone@gmail.com</a>
Samuel Smith	<a href="mailto:samandbettysmith@bellsouth.net">samandbettysmith@bellsouth.net</a>
Tommy T. Travis	<a href="mailto:tommyt4dekalb@gmail.com">tommyt4dekalb@gmail.com</a>
Norma Washington	<a href="mailto:nahwash4ms@aol.com">nahwash4ms@aol.com</a>

October 10, 2022



## DeKalb County Neighborhood Registry - Commission District 3

Last Name	First Name	Email	Address	City	State
Berry	Elfreda	berrylefreda227@gmail.com			
Bond	Beth	bethbond@bellsouth.net			
Craig	Pat	pat.lawrencecraig@gmail.com	3830 Brookview Point	Decatur	GA
Hodby	Peggy	phthompson3@msn.com			
Jackson	Nettie	NettieJackson@me.com	3714 Valpariso Circle	Decatur	GA
Jones	Carolyn	carolyn.jones818@yahoo.com			
Pringle	Willie	apringle@bellsouth.net			
Smith	Samuel	samandbettysmith@bellsouth.net			
Travis	Tommy	TommyTTravisconsulting@gmail.com			
Washington	Norma	nahwash4ms@aol.com			
Harris	Tene	tharris@galleryatsouthdekalb.com	2801 Candler Rd	Decatur	GA
Sanders	Christopher	csanders@eastmetrocid.com	2724 Wesley Chapel Road #360909	Decatur	GA
Wayne	Powell	Pdk-powell@comcast.net	P.O. 374	Decatur	GA
Roark	Rob	robroark@allsouthwarehouse.com	1775 Continental Way	Atlanta	GA
Gross	Joel L.	kgross@stickybusiness.net	4140 Bonsal Road	Conley	GA
Roark	Rob	robroark@allsouthwarehouse.com			
Hassan	Ali	AliHasanandassociates.com	3496 Midway	Decatur	GA
Locks	Danita	dlocks1019@aol.com	1211 Crescentwood Lane	Decatur	GA
Stephens	Sandra	sls1289@gmail.com	1289 Crescentwood Lane	Decatur	GA
Frank	Leanne	leannef@lightnountain.com	3141 Bonway Dr	Decatur	GA
Golley	Frank	frank@golleyrealty.com	3392 Midway Rd	Decatur	GA
Funk	Melanie	mfunk64@att.net	3392 Midway Rd	Decatur	GA
Barrow	Rachel	rbarrow@comcast.net	3355 Beech Dr	Decatur	GA
Preston	Judy	hjpreston23@gmail.com	2305 Bailey St		
Lips	Erik		1307 Crescent Wood Lane	Decatur	GA
Akins	Pat		3347 Beech Dr	Decatur	GA
Berlinsky	Samantha	saberlinsky@gmail.com	1301 Crescentwood Lane	Decatur	GA
McGannon	Monica	mhand27@gahoe.com	1305 Crescentwood Lane		
Gross	Joel	kgross@stickybusiness.net	4140 Bonsal Rd	Conley	GA
Arnold	Sandra	edsan@bellsouth.net	4296 Cedar Valley Court	Conley	GA
Barnes, AIA	Vernell	barnesve@yahoo.com	3826 Loyola Court	Decatur	GA
Evans	John	naacpdek@comcast.net	3011 Rainbow Drive, Suite 180A	Decatur	GA
Pace	Brenda	bcpace2@gmail.com	2638 Glenvalley Drive	Decatur	GA
Roberts	Regenia	regeniaroberts@bellsouth.net			
Culp	Patricia	ppculp@att.net			
Dennis	Robert	christinedennis@bellsouth.net	1987 Joseph Court	Decatur	GA
Bonino	Doninck	dbonino1@aol.com	4125 Milton Parkway	Alpharetta	GA



# Exhibit - D

404.371.2155 (o)  
404.371.4556 (f)  
DeKalbCountyGa.gov

178 Sams Street  
Decatur, GA 30030

## DEPARTMENT OF PLANNING & SUSTAINABILITY

### AUTHORIZATION

The property owner should complete this form or a similar signed and notarized form if the individual who will file the application with the County is not the property owner.

Date: 6/17/23

TO WHOM IT MAY CONCERN:

(I) (WE) CYRIL NWOJA

Name of owner(s)

being (owner) (owners) of the subject property described below or attached hereby delegate authority to

Cecil Francis for Stix & Stones Homes, LLC

Name of Agent or Representative

to file an application on (my) (our) behalf.

M. Nandaben B. Patel 06/17/2023  
Notary Public

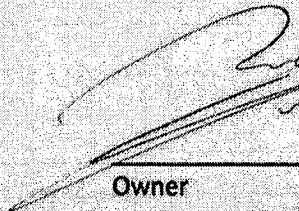
  
Owner

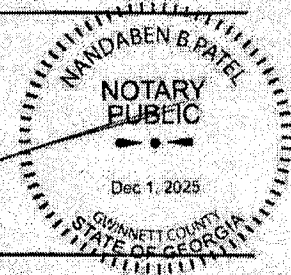

\_\_\_\_\_  
Notary Public

\_\_\_\_\_  
Owner

\_\_\_\_\_  
Notary Public

\_\_\_\_\_  
Owner

\_\_\_\_\_  
Notary Public

\_\_\_\_\_  
Owner

EXHIBIT "A"

ALL THAT TRACT OR PARCEL OF LAND LYING AND BEING IN LAND LOT 186, 15TH DISTRICT, DEKALB COUNTY, GEORGIA, AND BEING MORE PARTICULARLY DESCRIBED AS FOLLOWS: TO FIND THE TRUE POINT OF BEGINNING, BEGIN AT THE INTERSECTION OF THE ORIGINAL EASTERLY RIGHT-OF-WAY OF COLUMBIA DRIVE AND THE SOUTHERLY RIGHT-OF-WAY OF BOBOLINK DRIVE, AND RUNNING THENCE SOUTHERLY ALONG SAID ORIGINAL EASTERLY RIGHT-OF-WAY OF COLUMBIA DRIVE A DISTANCE OF 452.5 FEET TO A POINT; RUNNING THENCE NORTH 79 DEGREES 52 MINUTES 54 SECONDS EAST A DISTANCE OF 1.81 FEET TO A REBAR FOUND ON THE EASTERLY RIGHT-OF-WAY OF COLUMBIA DRIVE (RIGHT-OF-WAY VARIES), BEING THE TRUE POINT OF BEGINNING; FROM SAID TRUE POINT OF BEGINNING RUNNING THENCE NORTH 79 DEGREES 52 MINUTES 54 SECONDS EAST A DISTANCE OF 293.14 FEET TO AN OPEN TOP PIPE FOUND; RUNNING THENCE SOUTH 30 DEGREES 25 MINUTES 39 SECONDS EAST A DISTANCE OF 140.74 FEET TO AN OPEN TOP PIPE FOUND; RUNNING THENCE NORTH 58 DEGREES 44 MINUTES 43 SECONDS EAST A DISTANCE OF 56.17 FEET TO A REBAR FOUND; RUNNING THENCE SOUTH 28 DEGREES 05 MINUTES 20 SECONDS EAST A DISTANCE OF 51.10 FEET TO AN IRON PIN PLACED; RUNNING THENCE SOUTH 41 DEGREES 26 MINUTES 15 SECONDS EAST A DISTANCE OF 130.00 FEET TO A REBAR FOUND; RUNNING THENCE SOUTH 63 DEGREES 18 MINUTES 28 SECONDS WEST A DISTANCE OF 337.27 FEET A REBAR FOUND ON SAID EASTERLY RIGHT-OF-WAY OF COLUMBIA DRIVE; RUNNING THENCE NORTHERLY ALONG SAID RIGHT-OF-WAY ALONG A CURVE TO THE RIGHT AN ARC DISTANCE OF 49.30 FEET (SAID ARC BEING SUBTENDED BY A 49.29 FOOT CHORD BEARING NORTH 46 DEGREES 57 MINUTES 00 SECONDS WEST, WITH A RADIUS OF 1206.73 FEET TO A POINT; RUNNING THENCE NORTHERLY ALONG SAID RIGHT-OF-WAY ALONG A CURVE TO THE RIGHT AN ARC DISTANCE OF 148.93 FEET (SAID ARC BEING SUBTENDED BY A 148.40 FOOT CHORD BEARING NORTH 37 DEGREES 23 MINUTES 37 SECONDS WEST, WITH A RADIUS OF 508.77 FEET) TO A REBAR FOUND; RUNNING THENCE NORTH 29 DEGREES 00 MINUTES 27 SECONDS WEST ALONG SAID RIGHT-OF-WAY A DISTANCE OF 40.49 FEET TO A POINT; RUNNING THENCE NORTHERLY ALONG SAID RIGHT-OF-WAY ALONG A CURVE TO THE RIGHT AN ARC DISTANCE OF 107.17 FEET (SAID ARC BEING SUBTENDED BY A 107.13 FOOT CHORD BEARING NORTH 26 DEGREES 29 MINUTES 22 SECONDS WEST, WITH A RADIUS OF 1219.19 FEET) TO A POINT; RUNNING THENCE NORTH 23 DEGREES 58 MINUTES 16 SECONDS WEST ALONG SAID RIGHT-OF-WAY A DISTANCE OF 56.80 FEET TO A REBAR FOUND, BEING THE TRUE POINT OF BEGINNING; SAID PARCEL BEING SHOWN AS TRACT 'A' AND TRACT 'B' ON, AND CONTAINING A TOTAL OF 2.56 ACRES ACCORDING TO, PLAT OF SURVEY FOR THE CHRISTIAN JUBILEE FULL WORD BAPTIST CHURCH INC., DATED 08/03/09, BY SOLAR LAND SURVEYING COMPANY, JOHN W. STANZILIS, JR., G.R.L.S. NO. 2109 (JOB # 09-02090).

BEING IMPROVED PROPERTY MORE COMMONLY KNOWN AS 1484 COLUMBIA DRIVE, DECATUR, GA 30032; AND BEING THE SAME PROPERTY CONVEYED VIA DEED RECORDED IN DEED BOOK 21733 PAGE 441 DEKALB COUNTY RECORDS

TAX ID: 15-186-04-028

As to 1520R Columbia Circle

All that tract or parcel of land lying and being in Land Lot 186 of the 15th District of DeKalb County, Georgia, being Lot 4, Block A, Columbia Drive Subdivision Unit No. 2, according to the plat of record at Plat Book 18, Page 7, DeKalb County records, and being more particularly described as follows: BEGINNING at an iron pin on the northwesterly side of North Columbia Circle, 246 feet northeasterly, as measured along the northwesterly side of North Columbia Circle, from its intersection with the northeasterly side of Columbia Drive; running thence northeasterly along the northwesterly side of North Columbia Circle 67 feet to an iron pin; running thence northwesterly 251.7 feet to an iron pin; running thence southwesterly 118.7 feet to an iron pin; running thence southeasterly 100 feet to an iron pin; running thence southwesterly 44 feet to an iron pin; running thence southeasterly 188.2 feet to the iron pin on the northwesterly side of North Columbia Circle and the point of beginning. LESS AND EXCEPT:

**Clerk of Superior Court**

All that tract or parcel of land lying and being in Land Lot 186 of the 15th District of DeKalb County, Georgia, being part of Lot 4, Block A, Columbia Drive Subdivision Unit No. 2, according to the plat of record at Plat Book 18, Page 7, DeKalb County records, and being more particularly described as follows: BEGINNING at an iron pin on the northwesterly side of North Columbia Circle, 246 feet northeasterly, as measured along the northwesterly side of North Columbia Circle, from its intersection with the northeasterly side of Columbia Drive; running thence northeasterly along the northwesterly side of North Columbia Circle 67 feet to an iron pin; running thence northwesterly 157.51 feet to an iron pin; running thence southwesterly and forming an interior angle of 96 degrees 58 minutes 35 seconds with the last described course, 134.45 feet to an iron pin; running thence southeasterly 188.2 feet to the iron pin on the northwesterly side of North Columbia Circle and the point of beginning. Said less and except being the same property conveyed to Billy R. Oliver by Deed dated 12/7/73 and recorded in Deed Book 3114, Page 514, DeKalb County, Georgia Records

Being improved property more commonly known as 1520 R Columbia Circle Decatur, GA 30032 and being the same property conveyed via deed recorded in Deed Book 23793 Page 784 DeKalb County Records,

Tax ID 15-186-04-029

**SITE PHOTOGRAPHS**



**TITLE EXCEPTIONS - Tract One (2.575 acres)**

THE FOLLOWING EXCEPTIONS ARE LISTED IN SCHEDULE B, SECTION 2, OF A COMMITMENT FOR TITLE INSURANCE, AS PREPARED BY FIDELITY NATIONAL TITLE INSURANCE COMPANY, COMMITMENT NO. 210428, EFFECTIVE DATE AUGUST 3, 2021.  
RIGHT OF WAY DEED recorded in Deed Book 1645, Page 349, DeKalb County Records, AFFECTS SITE - BLANKET EASEMENT FOR DRAINAGE - NOT PLOTTABLE

**TITLE EXCEPTIONS - Tract Two (0.220 acres)**

THE FOLLOWING EXCEPTIONS ARE LISTED IN SCHEDULE B, SECTION 2, OF A COMMITMENT FOR TITLE INSURANCE, AS PREPARED BY FIDELITY NATIONAL TITLE INSURANCE COMPANY, COMMITMENT NO. 210428, EFFECTIVE DATE AUGUST 3, 2021.  
- All matters and exceptions appearing at Plat Book 18 Page 7 aforesaid records.  
NO EASEMENTS AFFECTING SITE ARE DEPICTED ON DOCUMENT

**PROPERTY DESCRIPTION**

OVERALL PROPERTY DESCRIPTION  
All that tract or parcel of land lying or being in Land Lot 186, 15th District, DeKalb County, Georgia, and being more particularly described as follows:

Commencing at the intersection of the Northwesterly right-of-way of Columbia Circle (80 foot right-of-way) with the Northeasterly right-of-way of Columbia Drive (variable right-of-way); thence along said right-of-way of Columbia Drive, in a Northwesterly direction, 338.33 feet to a 5/8 inch rebar set, said point having State Plane Coordinates of North 1,362,354.00, East 2,268,038.08, Georgia West Zone, said point being the True Point of Beginning;

Thence continuing along said right-of-way, along a curve to the right, said curve having an arc length of 51.40 feet with a radius of 1206.73 feet, being subtended by a chord bearing of North 45 degrees 50 minutes 46 seconds West, a distance of 51.40 feet to a point; thence along a curve to the right, said curve having an arc length of 148.93 feet with a radius of 508.77 feet, being subtended by a chord bearing of North 36 degrees 14 minutes 23 seconds West, a distance of 148.40 feet to a point; thence North 27 degrees 51 minutes 13 seconds West, a distance of 40.49 feet to a point; thence along a curve to the right, said curve having an arc length of 107.13 feet with a radius of 1219.19 feet, being subtended by a chord bearing of North 25 degrees 20 minutes 08 seconds West, a distance of 107.13 feet to a point; thence North 22 degrees 49 minutes 02 seconds West, a distance of 66.40 feet to a 1/2 inch rebar found; thence leaving said right-of-way North 81 degrees 13 minutes 33 seconds East, a distance of 295.23 feet to a 1/2 inch rebar found; thence South 29 degrees 08 minutes 36 seconds East, a distance of 140.87 feet to a 1/2 inch open top pipe found; thence North 60 degrees 01 minutes 46 seconds East, a distance of 56.14 feet to a 5/8 inch rebar set; thence South 28 degrees 48 minutes 17 seconds East, a distance of 51.07 feet to a 5/8 inch rebar set; thence South 40 degrees 09 minutes 12 seconds East, a distance of 128.94 feet to a 1/2 inch rebar found; thence North 64 degrees 35 minutes 01 seconds East, a distance of 71.42 feet to a 1/2 inch rebar found; thence South 32 degrees 48 minutes 55 seconds East, a distance of 93.72 feet to a 5/8 inch rebar set; thence South 64 degrees 37 minutes 54 seconds West, a distance of 89.76 feet to a 5/8 inch rebar set; thence North 49 degrees 24 minutes 28 seconds West, a distance of 100.52 feet to a 1/2 inch rebar found; thence South 64 degrees 32 minutes 34 seconds West, a distance of 289.94 feet to a 5/8 inch rebar set, said point being the True Point of Beginning.

Said tract of land contains 2.795 Acres.

**VICINITY MAP**

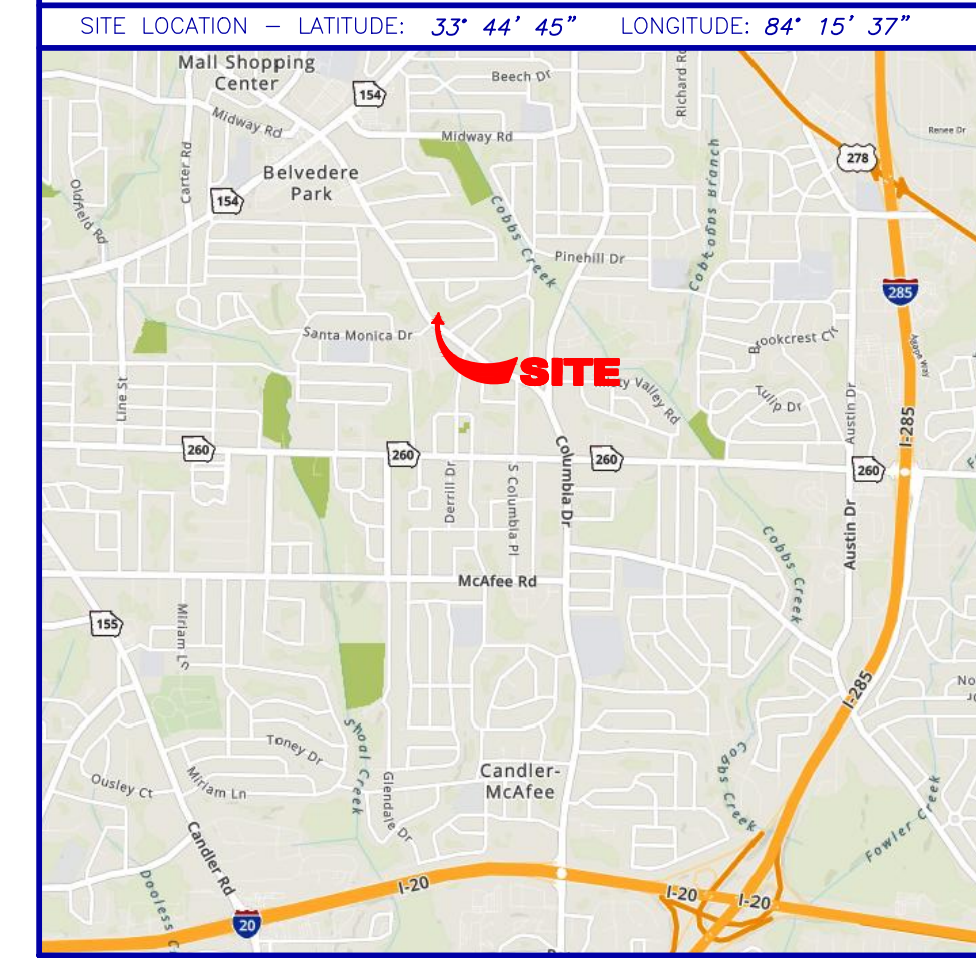

**GENERAL NOTES**

THIS SURVEY HAS BEEN PREPARED FOR THE EXCLUSIVE USE OF THE PERSON OR ENTITIES NAMED HEREON, NO EXPRESS OR IMPLIED WARRANTIES WITH RESPECT TO THE INFORMATION SHOWN HEREON IS TO BE EXTENDED TO ANY PERSONS OR ENTITIES OTHER THAN THOSE SHOWN HEREON.  
REVISIONS LISTED ON THIS SURVEY APPLY ONLY TO THE SPECIFIC CHANGES REFERENCED, AND DO NOT CONSTITUTE AN UPDATE OF OTHER DATA ON THIS SURVEY. THE "SURVEY DATE" SHOWN HEREON IS THE APPLICABLE DATE AS RELATED TO PROVISIONS OF STATUTES OF LIMITATION UNLESS SPECIFICALLY NOTED OTHERWISE.

THIS PROPERTY IS NOT LOCATED IN A SPECIAL FLOOD HAZARD AREA BASED ON THE FLOOD INSURANCE RATE MAP FOR THIS AREA. THE MAP NUMBER FOR THIS AREA IS 130803231A, AND THE DATE OF SAID MAP IS MAY 16, 2013. THIS DETERMINATION WAS MADE BY GRAPHICALLY DETERMINING THE POSITION OF THIS SITE ON SAID FIRM MAPS UNLESS OTHERWISE NOTED.

PLEASE NOTE: TREES 6-INCH DBH (DIAMETER AT BREAST HEIGHT) AND LARGER WERE LOCATED FOR THIS SURVEY.  
PLEASE NOTE: ABOVE GROUND UTILITIES ARE SHOWN HEREON. NO UNDERGROUND UTILITIES WERE MARKED OR LOCATED.

RIGHT-OF-WAY LINES SHOWN ON THIS SURVEY THAT ARE NOT ACTUAL BOUNDARIES OF THE SUBJECT TRACT(S) ARE DEPICTED GRAPHICALLY AND ARE SHOWN APPROXIMATELY FOR INFORMATIONAL PURPOSES ONLY. SAID RIGHT-OF-WAY LINES SHOULD NOT BE UTILIZED FOR DESIGN PURPOSES.

THE DATUM FOR THIS SITE WAS ESTABLISHED UTILIZING GLOBAL POSITIONING SYSTEMS, AND BASED ON POSITIONAL VALUES FOR THE VIRTUAL REFERENCE STATION NETWORK DEVELOPED BY eGPS SOLUTIONS. THE HORIZONTAL REFERENCE FRAME IS NORTH AMERICAN DATUM OF 1983 (NAD83). THE VERTICAL REFERENCE FRAME IS NORTH AMERICAN VERTICAL DATUM OF 1988. ANY DIRECTIONS OR DIMENSIONS SHOWN ARE A RECTANGULAR, GROUND LEVEL PROJECTION OF THE STATE PLANE COORDINATE SYSTEM.

NO ZONING REPORT OR ZONING LETTER WAS PROVIDED TO THE SURVEYOR. THE SITE IS ZONED "R-75" (RESIDENTIAL MEDIUM LOT-75 DISTRICT) AS SHOWN ON THE ZONING MAP OF DEKALB COUNTY.  
THE MINIMUM YARD SETBACKS ARE:  
FRONT (THOROUGHFARE) - 45 FEET, FRONT (ARTERIALS) - 35 FEET, FRONT (COLLECTOR & OTHER STREETS) - 30 FEET  
SIDE - 7.5 FEET, REAR - 40 FEET.

PLEASE NOTE: ZONING AND SETBACKS SHOULD BE CONFIRMED AND VERIFIED BY PLANNING AND ZONING PRIOR TO DESIGN OR CONSTRUCTION ACTIVITIES.

(CLERK OF COURT RECORDING INFORMATION)

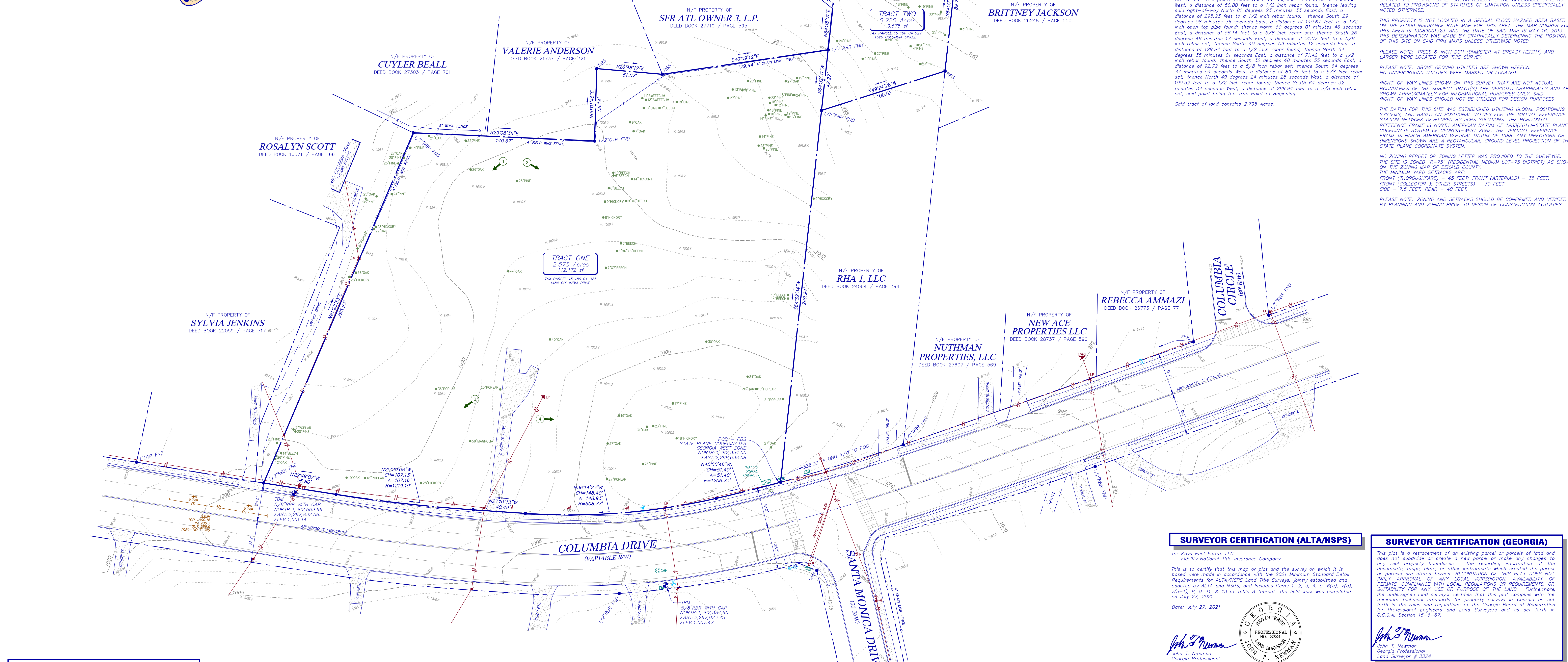
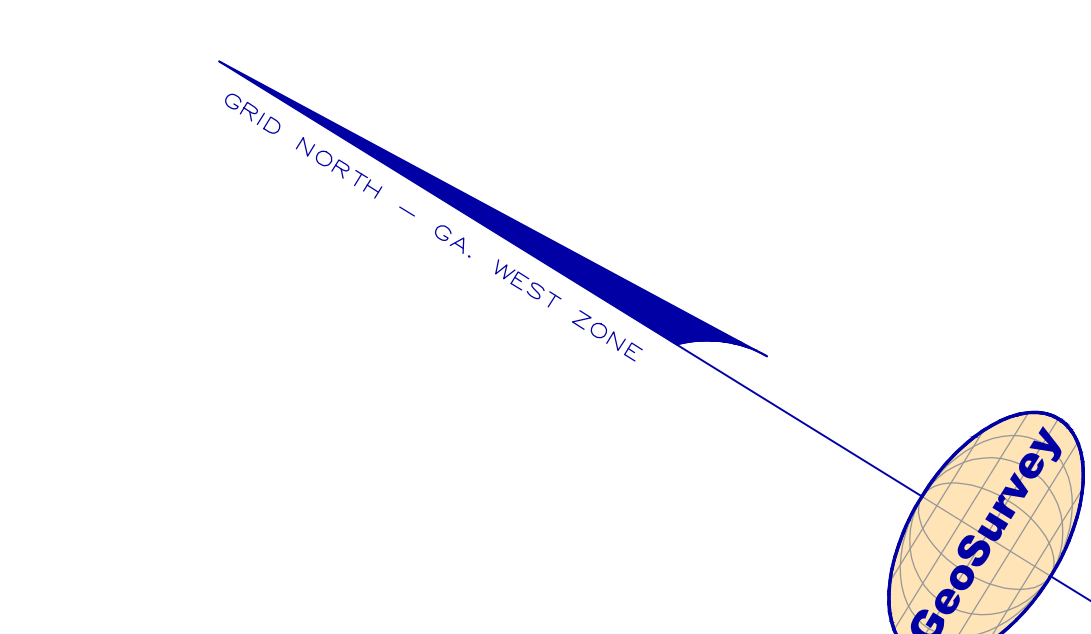

**SURVEYOR CERTIFICATION (ALTA/NSPS)**

To: Kova Real Estate LLC  
Fidelity National Title Insurance Company  
This is to certify that this map or plat and the survey on which it is based were made in accordance with the 2021 Minimum Standard Detail Requirements for ALTA/NSPS Land Title Surveys, jointly established and adopted by ALTA and NSPS, and includes Items 1, 2, 3, 4, 5, 6(a), 7(a), 7(b-1), 8, 9, 11, & 13 of Table A thereof. The field work was completed on July 27, 2021.  
Date: July 27, 2021

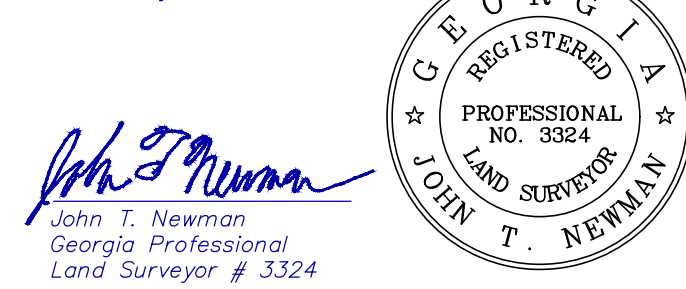

**SURVEYOR CERTIFICATION (GEORGIA)**

This plat is a retracement of an existing parcel or parcels of land and does not subdivide or create a new parcel or make any changes to any real property boundaries. The recording information of the documents, maps, plats, or other instruments which created the parcel or parcels are stated hereon. RECORDATION OF THIS PLAT DOES NOT IMPLY APPROVAL OF ANY LOCAL JURISDICTION, AVAILABILITY OF PERMITS, COMPLIANCE WITH LOCAL REGULATIONS, REQUIREMENTS, OR SUITABILITY FOR ANY USE OR PURPOSE OF THE LAND. Furthermore, the undersigned land surveyor certifies that this plat complies with the minimum technical standards for property surveys in Georgia as set forth in the rules and regulations of the Georgia Board of Registration for Professional Engineers and Land Surveyors and as set forth in O.C.G.A. Section 15-6-67.



**LEGEND**

STANDARD ABBREVIATIONS	STANDARD SYMBOLS
AC AIR CONDITIONER	OT OVERHEAD TRAFFIC SIGNAL LIGHT
BH BORE HOLE	PP POWER POLE
BSL BUILDING SETBACK LINE	QW QUIET WIRE
C CURB INLET	PL POWER LINE
CMF CORRUGATED METAL PIPE	LP LIGHT POLE
CS CONCRETE MONUMENT FND	ET ELECTRIC TRANSFORMER
CP SANITARY CLEANOUT	W WATER VAULT
CPED COMMUNICATION PEDESTAL	GV GAS VALVE
CTP CROWNED TOP PIPE	GM GAS METER
DI DROP INLET	WV WATER VALVE
DWB DOUBLE WIND CATCH BASIN	WM WATER METER
FNC FENCE	JB JUNCTION BOX
FM FOUND	JH MANHOLE
GM GAS METER	OCS OUTLET CONTROL STRUCTURE
INV INVERT	OP OPEN TOP PIPE
JB JUNCTION BOX	PM POWER METER
JH MANHOLE	POB POINT OF BEGINNING
OCS OUTLET CONTROL STRUCTURE	POC POINT OF COMMENCEMENT
OP OPEN TOP PIPE	RF REINFORCED CONCRETE PIPE
PM POWER METER	RIB IRON REINFORCING BAR
POB POINT OF BEGINNING	RIS 5/8" RIB SET CARRIED FSZ 621
POC POINT OF COMMENCEMENT	SS SANITARY SEWER
RF REINFORCED CONCRETE PIPE	SWB SINGLE WIND CATCH BASIN
RIB IRON REINFORCING BAR	TRANS ELECTRIC TRANSFORMER
RIS 5/8" RIB SET CARRIED FSZ 621	
SS SANITARY SEWER	
SWB SINGLE WIND CATCH BASIN	
TRANS ELECTRIC TRANSFORMER	

**CLOSURE STATEMENT**

THE FIELD CLOSURE UPON WHICH THIS PLAT IS BASED HAS A CLOSURE PRECISION OF ONE FOOT IN 108,564, AND WAS ADJUSTED USING THE LEAST SQUARES METHOD. A TRIMBLE S-4 TOTAL STATION AND TRIMBLE TSC-3 DATA COLLECTOR WERE USED TO COLLECT THIS FIELD DATA.  
THIS PLAT HAS BEEN CALCULATED FOR CLOSURE AND WAS FOUND TO BE ACCURATE WITHIN ONE FOOT IN 388,724 FEET 1/10" INV.

**IF YOU DIG**

**811** Know what's below. Call before you dig. Dial 811 Or Call 800-282-7411

**GRAPHIC SCALE**

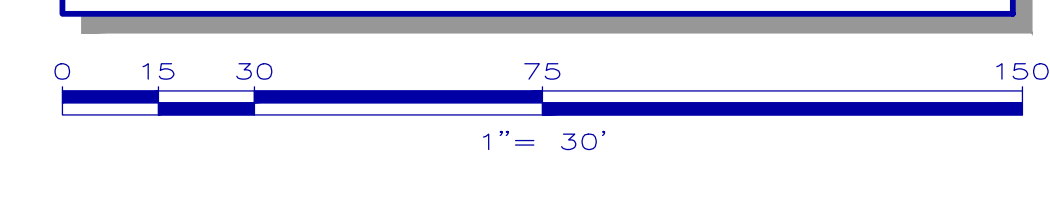

N/F PROPERTY OF  
**THE CHRISTIAN JUBILEE FULL WORD BAPTIST CHURCH, INC.**  
DEED BOOK 21733 / PAGE 441  
DEED BOOK 23793 / PAGE 781

TRACT ONE 2.575 Acres 112,172 sf  
TRACT TWO 0.220 Acres 9,578 sf

**TOTAL SITE AREA 2,795 Acres 121,750 sf**

**GeoSurvey**  
Land Surveying • 3D Laser Scanning  
1660 Barnes Mill Road Marietta, Georgia 30062  
Phone: (770) 795-9900  
Fax: (770) 795-8880  
www.geosurvey.com  
Certificate of Authorization #LSF-000621

ALTA/NSPS LAND TITLE SURVEY			
1484 Columbia Drive			
FOR			
<b>Kova Real Estate LLC</b>			
<b>Fidelity National Title Insurance Company</b>			
GS JOB NO:	20217054	DRAWING SCALE:	1" = 30'
FIELD WORK:	CS	CITY:	UNINCORPORATED
PROJ MGR:	JTN	COUNTY:	DEKALB
REVIEWED:	DLH	STATE:	GA
DWG FILE:	20217054-01.dwg	LAND LOT:	186
		DISTRICT:	15TH
SURVEY DATE:	07-27-2021	REVISIONS (SEE GENERAL NOTES)	
No.:	Date:	Description:	
1:	8-9-21	ADD ALTA notes	

2022-1477

**SUBSTITUTE**

**RECOMMENDED ZONING CONDITIONS**

**07-26-2022 (as amended by the BOC)**

1. The development shall have a maximum of eleven (11), detached, single-family homes. General compliance with the site plan received May 3, 2022, shall be required. The community must establish a homeowners' or property owners' association (HOA or POA) per the *Zoning Ordinance* and *Land Development Code*. The HOA/POA shall limit the number of rental units to 10% of the total homes constructed.
2. All home designs shall be consistent with the enclosed color rendering entitled "2021-12-20\_11-19-43," including the following building materials: cementitious hardie plank, vinyl glass windows, shingle roofing, metal roofs over porches, stained cedar plank for post beams and gable crosses, and vinyl garage doors, and must comply with the applicable provisions of Article 5 of the *Zoning Ordinance* related to building form and design.
3. The developer shall construct at least one, stacked stone, monument, subdivision sign on community property along Columbia Drive (as enclosed). Signage shall comply with applicable sections of the *Sign Ordinance*.
4. Signs shall be posted inside the community and at the curb cut on Columbia Drive to indicate that the southernmost driveway is one-way only into the property.
5. The approval of this rezoning application by the Board of Commissioners has no bearing on other approvals by the Zoning Board of Appeals or other authority, whose decision should be based on the merits of the application before said authority.

## LETTER OF APPLICATION

This application seeks to modify rezoning conditions established for application Z-22-1245496.

The Subject Property was approved for the development of eleven (11), detached single family homes.

The Applicant hopes to redevelop the site with (20) single family cottage-style single family homes on fee simple lots. The development is modeled on the Cottages at Vaughn ([www.microlifeinstitute.org](http://www.microlifeinstitute.org)) an award winning micro-cottage development in Dekalb County and the City of Clarkston providing small homes arranged around a common areas and green space, the cottages at Vaughn contains 8 micro-units on ½ acre (16 units per-acre). The units' range in size from +/- 260-500 square feet. They are one to one and a half stories in height and clustered around a central green. They also share a common parking lot.

Stix and Stones Homes, LLC plans to emulate the concept while providing larger single family cottage homes ranging in size from 1100 – 1200 SF. The development proposed will contain 20 cottage-style homes on 2.795 acres (7.3 units per-acre (the "Proposed Development"). Similar to the Cottages at Vaughn, the units will be one to one- and one-half stories in height, clustered around central green space and shared parking lots. A total of (8) units will have driveways that allow off-street parking while the remaining (12) units will have shared parking spaces situated

to the East and West of the site. The design provides connectivity to the shared green space and community pavilion through sidewalks situated throughout the development.

A Site Plan has been filed with the application, along with other required materials. To the applicant's knowledge, no other major modification application has been filed concerning the Subject Property. The subject Property is zoned R60 and designated as "Suburban" on the County's Future Land Use Map and is convenient to a commercial corridor known as the Belvedere Shopping District.

*Cecil Francis*

---

Respectfully submitted,

Cecil Francis  
Stix & Stones Homes, LLC  
PO Box 4359  
Atlanta GA 30302  
404-454-6699



## IMPACT ANALYSIS

### A. WHETHER THE ZONING PROPOSAL IS IN CONFORMITY WITH THE POLICY AND INTENT OF THE COMPREHENSIVE PLAN.

Dekalb County has adopted the 2035 Comprehensive Plan (the “Plan”), which consists of text and series of maps. The Future Land Use Map designation for the Subject Property is “Suburban”, which is fully consistent and commensurate with the proposed use and fosters a number of general policies and strategies of the County’s Comprehensive Plan for the Suburban character area, including:

**Traditional Neighborhood Principles** – In appropriate locations encourage residential development to conform with traditional principles including a higher mix of uses.

**Residential Protection** – Protect stable neighborhoods from incompatible development that could alter established single-family residential development patterns and density. Protect single family stable neighborhoods adjacent Activity Centers from incompatible development that could alter established residential development patterns and density.

**Infill Development** – Enforce residential infill development regulations in efforts to preserve and stabilize existing neighborhoods.

**Density** – Promote moderate density, traditional neighborhood development style residential subdivisions, which may utilize alley ways and rear vehicular access, as well as automobile dependency.

**Street Design** – Promote Street design that fosters calming including narrower residential streets, on street parking, and the addition of bicycle and pedestrian facilities.

**Nodes** – Create neighborhood focal points through the use of existing pocket parks and squares for community activities.

**Architecture** – Encourage compatible architecture styles that maintain regional and neighborhood character.

In summary, the proposed development serves to implement specific goals, objectives, and policies of the City’s Comprehensive Plan. The project at issue represents a consistent use commensurate with other existing uses on adjacent and nearby properties. The proposed use therefore is suitable vis-à-vis the policies of the Comprehensive Plan.

**B. WHETHER THE ZONING PROPOSAL WILL PERMIT A USE THAT IS SUITABLE IN VIEW OF THE USE AND DEVELOPMENT OF ADJACENT AND NEARBY PROPERTY OR PROPERTIES.**

Yes. The Subject Property sits in transition between (2) single family homes (1512 Columbia Drive and 1460 Columbia Drive). Except for 1473 Columbia Drive, located directly to the north of the Subject Property zoned MR-2, the remaining single-family homes are zoned R75. The existing R60 zoning is consistent with the majority of the R75 zoned parcels that allow for single-family detached housing options. “The Proposed Development offers a housing option that is consistent with the existing homes in size and scope of construction.

The final appearance of this development will include appropriate attention to scale, buffering, setbacks and landscaping so that this development will blend harmoniously with its surroundings. **The maximum height of 1.5 stories will prevent the project from overwhelming adjoining homes in scale.** The proposed homes will provide an elegant and attractive design that will offer much needed upscale housing stock, at an affordable price, in a community that has experienced rapid home price inflation. Therefore, the requested zoning district is therefore entirely consistent with and suitable in light of the current and future development plans and patterns,

**C. WHETHER THE PROPERTY TO BE AFFECTED BY THE ZONING PROPOSAL HAS A REASONABLE ECONOMIC USE AS CURRENTLY ZONED**

Yes. The subject property is zoned R60.

**D. WHETHER THE ZONING PROPOSAL WILL ADVERSELY AFFECT THE EXISTING USE OR USABILITY OF ADJACENT OR NEARBY PROPERTY OR PROPERTIES.**

No. The primary goal of land use planning is to eliminate or minimize the potential adverse effect of the dissimilar uses of adjacent tracts of land by establishing a harmonious transition

between them. The traditional method of achieving this goal is through both “off-site” and “on-site” transition. Off-site transition consists of avoiding the placement of dissimilar uses next to each other by placing uses of intermediate density between them. On-site transition, which might either supplement or replace off-site transition, consist of measures imposed on or adjacent to the more intensive use to protect neighborhoods from adverse effects. Thus, this method of land use planning includes measures such as maintenance of buffers; walls, fences or berms; lighting control; noise control; aesthetic control; limitations on building location and orientation; location of or restrictions upon accessory uses; and prohibition of certain uses or hours of use normally permitted for that district. Many of these devices have been or will be utilized in this application.

Located between attached single family homes and detached homes, the Proposed Development will pay careful attention to scale, buffering, setbacks and landscaping so that it will blend and complement the adjacent developments. Accordingly, approving our request for a modification will not adversely affect the nearby existing uses and will enhance the adjacent properties.

**E. WHETHER THERE ARE OTHER EXISTING OR CHANGING CONDITION AFFECTING THE USE AND DEVELOPMENT OF THE PROPERTY WILL GIVE SUPPORTING GROUNDS FOR EITHER APPROVAL OR DISAPPROVAL OF THE ZONING PROPOSAL.**

No. The proposal is merely a request to modify the density of homes from (11) single family units to (20) single family cottage units.

**F. WHETHER THE ZONING PROPOSAL WILL ADVERSELY AFFECT HISTORIC BUILDINGS, SITES, DISTRICTS OR ARCHAEOLOGICAL RESOURCES.**

The Applicant is not aware of any historic buildings, sites, districts, or archeological resources either on the Subject property or located in the immediate vicinity that would suffer adverse impacts from the rezoning requested.

**G. WHETHER THE REQUESTED REZONING WILL NOT RESULT IN A USE WHICH WILL OR COULD CAUSE EXCESSIVE OR BURDENSOME USE OF EXISTING STREETS, TRANSPORTATION FACILITIES, UTILITIES OR SCHOOLS.**

No The proposed development will not overly burden existing streets or transportation facilities. The ITE Trip generation Manual does not have data on this type of cottage-style , urban single family community, which has more single-person occupancy and fewer car counts than a traditional single-family detached neighborhood. Therefore, traditional ITE data is likely overstated. With that said, the ITE data states that sixteen (16) single family detached homes

(ITE category 210) will generate 12.32 trips during the AM peak hour and 16.32 trips during the PM peak hour. As for utilities, the Subject Properties have access to water and sewer. Finally, the proposed development will not create excessive or burdensome use of the community's schools. This type of development is not marketed towards families. Nonetheless, the Subject Property is served by Peachcrest Elementary School, Towers High School and Mary Mcleod Bethune Middle School, all of which are listed at, significantly, below capacity according to the enrollment and capacity data provided on the Dekalb County Schools Operations website.

**H. WHETHER THE ONING PROPOSAL ADVERSELY IMPACTS THE ENVIRONMENT OR SURROUNDING NATURAL RESOURCES.**

The Applicant will comply with all federal, state and city regulations relating to environmental protection to ensure that the proposed development will not adversely affect the environment.

**CONCLUSION**

For the foregoing reasons, the Applicant respectfully request that the Rezoning Application at issue be approved. The Applicant also invites and welcomes any comments from Staff or other officials of the County so that recommendations or input might be incorporated as conditions of approval of the Application.

This 24<sup>th</sup> day of August 2023

Respectfully submitted,

*Cecil Francis*

---

Stix & Stones Homes, LLC

Cecil Francis

Stix & Stones Homes, LLC

PO Box 4359

Atlanta, GA 30302

(404) 454-6699

Stixandstonesgeorgia@gmail.com



DEPARTMENT OF PLANNING & SUSTAINABILITY

DISCLOSURE OF CAMPAIGN CONTRIBUTION

In accordance with the Conflict of Interest in Zoning Act, OCGA Chapter 36-67A, the following questions must be answered.

Have you, the applicant, made \$250.00 or more in campaign contribution to a local government official within two years immediately preceding the filling of this application?

Yes \_\_\_ No \_\_\_\*

If the answer is yes, you must file a disclosure report with the governing authority of DeKalb County showing:

- 1. The name and official position of the local government official to whom the campaign contribution was made.
2. The dollar amount and description of each campaign contribution made during the two years immediately preceding the filing of this application and the date of each such contribution.

The disclosure must be filed within 10 days after the application is first filed and must be submitted to the C.E.O. and to the Board of Commissioners of DeKalb County, 1300 Commerce Drive, Decatur, GA 30030.

[Handwritten signature]
Notary

[Handwritten signature] 0.24.2023
Signature of Applicant / Date

Check one: Owner \_\_\_\_\_ Agent X

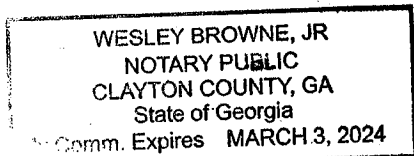

Expiration Date/ Seal

\*Notary seal not needed if answer is "no".

**AN ORDINANCE TO AMEND THE DEKALB COUNTY ZONING MAP**

**AN ORDINANCE TO REZONE PROPERTY FROM R-75 (RESIDENTIAL MEDIUM LOT-75) ZONING DISTRICT TO R-60 (RESIDENTIAL MEDIUM LOT-60) ZONING DISTRICT TO ALLOW AN 11-LOT SUBDIVISION FOR SINGLE-FAMILY DETACHED HOMES. THE PROPERTY IS LOCATED ON THE EAST SIDE OF COLUMBIA DRIVE, APPROXIMATELY 337 FEET NORTH OF COLUMBIA CIRCLE, AT 1484 COLUMBIA DRIVE (A.K.A. 1500 COLUMBIA DRIVE), AND 1520 COLUMBIA CIRCLE, DECATUR, GEORGIA. THE PROPERTY HAS APPROXIMATELY 406 FEET OF FRONTAGE ON COLUMBIA DRIVE (1484 COLUMBIA DRIVE) AN NO FRONTAGE (1520 COLUMBIA CIRCLE) AND CONTAINS 2.73 ACRES.**

**APPLICANT:** Kova Real Estate, LLC  
**OWNER:** Griffin & Davis Consulting, LLC

**COMMISSION DISTRICTS:** 3 & 7

**WHEREAS**, Kova Real Estate, LLC has filed an application to amend the DeKalb County Zoning Ordinance to rezone property located at 1484 Columbia Drive (a.k.a. 1500 Columbia Drive), and more particularly described as follows:

All that tract or parcel of land and being in **District 15, Land Lot 186, Block 04, Parcels 028 & 029** of DeKalb County, Georgia, containing 2.73 acres, and

**WHEREAS**, it appears to the Board of Commissioners that the application meets all of the criteria set forth in the DeKalb County Code, Chapter 27, Article VII, Division 3, Section 27-7.3 for amending the DeKalb County Zoning Ordinance for the subject property from R-75 zoning district to R-60 zoning district.

**THE BOARD OF COMMISSIONERS OF DEKALB COUNTY, GEORGIA, HEREBY ORDAINS:**

**Part 1:** Pursuant to the authority of the DeKalb County Board of Commissioners to exercise powers of zoning, set forth in Section 27, Article 1.1 and 7.3 of the DeKalb County Zoning Ordinance, an amendment to rezone property from R-75 (Residential Medium Lot-75) zoning district to R-60 (Residential Medium Lot-60) zoning district to allow an 11-lot subdivision for single-family detached homes. The property is located on the east side of Columbia Drive, approximately 337 feet north of Columbia Circle, at 1484 Columbia Drive (a.k.a. 1500 Columbia Drive), and 1520 Columbia Circle, Decatur, Georgia. The property has approximately 406 feet of frontage on Columbia Drive (1484 Columbia Drive) an no frontage (1520 Columbia Circle). The property contains 2.73 acres and is hereby approved, (with conditions).

**Part 2:** That this amendment is approved conditionally, and under the provisions of Section 27-7.3.9 of the DeKalb County Zoning Ordinance, as identified by the use of the term "Conditional" after the district designation in Part 1 above, the development and use of the above-described property shall be permitted only in compliance with the conditions and/or site plan as attached to this ordinance.

**Part 3:** That all ordinances or parts of ordinances in conflict with this ordinance are hereby repealed.

**Part 4:** This ordinance, hereby approved, does not authorize the violation of any Zoning District Regulations. District regulation variances can be approved in accordance with Chapter 27, Article VII, Division 5.

**ADOPTED** by the DeKalb County Board of Commissioners this \_\_\_\_\_ day of

\_\_\_\_\_ 2022.

---

Robert J. Patrick  
Presiding Officer  
Board of Commissioners  
DeKalb County, Georgia

ATTEST:

---

Barbara Sanders-Norwood, CCC  
Clerk to the Board of Commissioners and  
Chief Executive Officer  
DeKalb County, Georgia

**REQUESTED BY APPLICANT:**

Application of Kova Real Estate, LLC to rezone property from R-75 (Residential Medium Lot-75) to R-60 (Residential Medium Lot-60) to allow an 11-lot subdivision for single-family detached homes.

**PLANNING AND SUSTAINABILITY DEPARTMENT RECOMMENDATION:****Approval with Conditions (updated 7/26/2022).**

1. The development shall have a maximum of eleven (11), detached, single-family homes. General compliance with the site plan received May 3, 2022, shall be required. The community must establish a homeowners' or property owners' association (HOA or POA) per the *Zoning Ordinance* and *Land Development Code*. The HOA/POA shall limit the number of rental units to 10% of the total homes constructed.
2. All home designs shall be consistent with the enclosed color rendering entitled "2021-12-20\_11-19-43," including the following building materials: cementitious hardi plank, vinyl glass windows, shingle roofing, metal roofs over porches, stained cedar plank for post beams and gable crosses, and vinyl garage doors, and must comply with the applicable provisions of Article 5 of the *Zoning Ordinance* related to building form and design.
3. The developer shall construct at least one, stacked stone, monument, subdivision sign on community property along Columbia Drive (as enclosed). Signage shall comply with applicable sections of the *Sign Ordinance*.
4. Signs shall be posted inside the community and at the curb cut on Columbia Drive to indicate that the southernmost driveway is one-way only into the property.
5. The approval of this rezoning application by the Board of Commissioners has no bearing on other approvals by the Zoning Board of Appeals or other authority, whose decision should be based on the merits of the application before said authority.

**PLANNING COMMISSION RECOMMENDATION:**

**Full Cycle Deferral 6-0-0.** Vivian Moore moved, LaSonya Osler seconded for a Full Cycle Deferral to the July 2022 zoning agenda because the applicant presented a revised site plan at the meeting that has not yet seen by the community.

**BOARD of COMMISSIONERS FINAL ACTION:**

**July 26, 2022, Approved with Staff's recommended five (5) conditions, dated 7/26/2022.**



2022-1477

**SUBSTITUTE**

**RECOMMENDED ZONING CONDITIONS**

**07-26-2022 (as amended by the BOC)**

1. The development shall have a maximum of eleven (11), detached, single-family homes. General compliance with the site plan received May 3, 2022, shall be required. The community must establish a homeowners' or property owners' association (HOA or POA) per the *Zoning Ordinance* and *Land Development Code*. The HOA/POA shall limit the number of rental units to 10% of the total homes constructed.
2. All home designs shall be consistent with the enclosed color rendering entitled "2021-12-20\_11-19-43," including the following building materials: cementitious hardie plank, vinyl glass windows, shingle roofing, metal roofs over porches, stained cedar plank for post beams and gable crosses, and vinyl garage doors, and must comply with the applicable provisions of Article 5 of the *Zoning Ordinance* related to building form and design.
3. The developer shall construct at least one, stacked stone, monument, subdivision sign on community property along Columbia Drive (as enclosed). Signage shall comply with applicable sections of the *Sign Ordinance*.
4. Signs shall be posted inside the community and at the curb cut on Columbia Drive to indicate that the southernmost driveway is one-way only into the property.
5. The approval of this rezoning application by the Board of Commissioners has no bearing on other approvals by the Zoning Board of Appeals or other authority, whose decision should be based on the merits of the application before said authority.



ents Disabled

- Overall siding will be Cementitious Hardie plank panels and trims
- Vinyl glass windows
- Mostly shingle roofing with metal roof over few porches
- Stained Cedar plank for post beams and gable crosses
- Vinyl garage doors

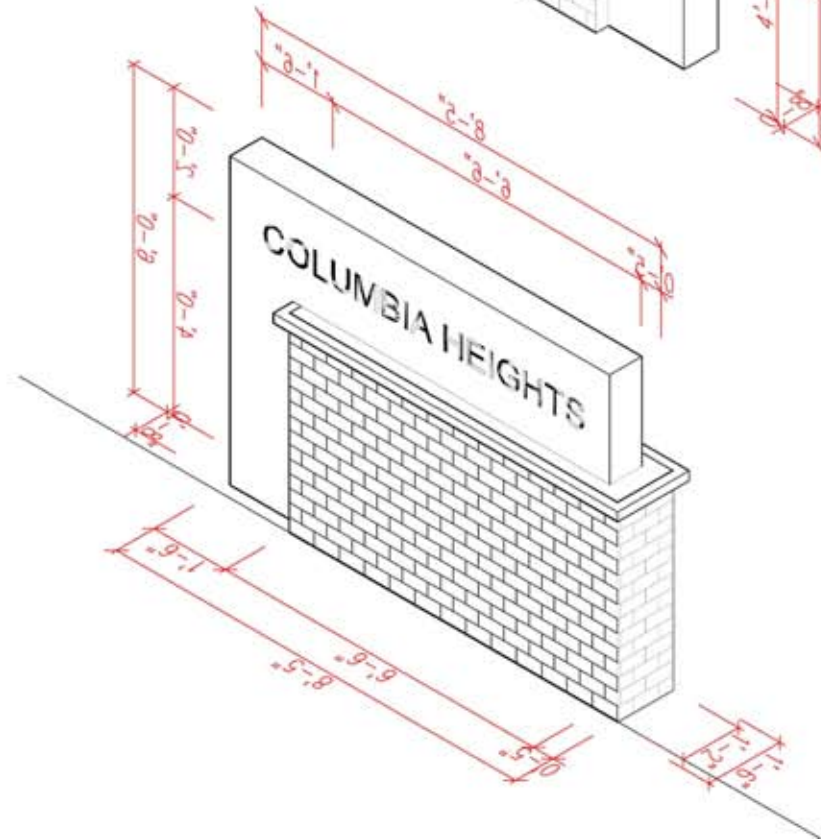
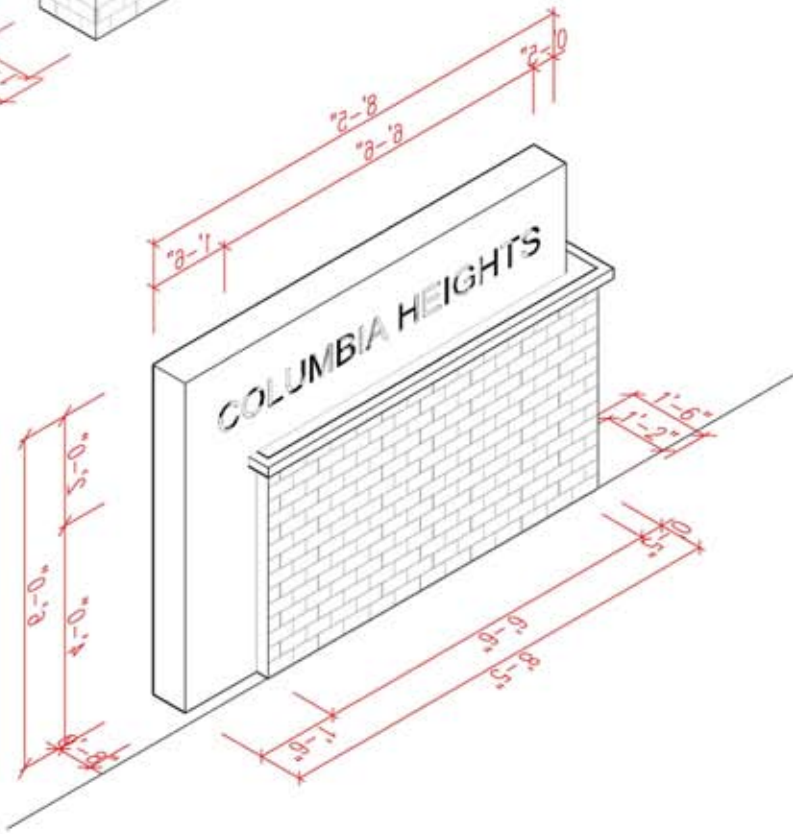
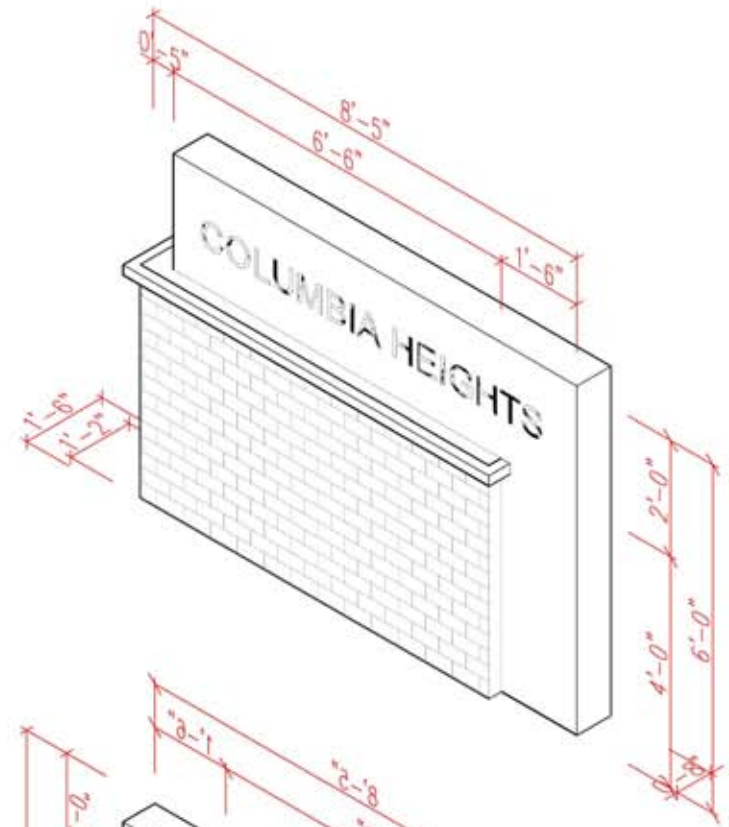
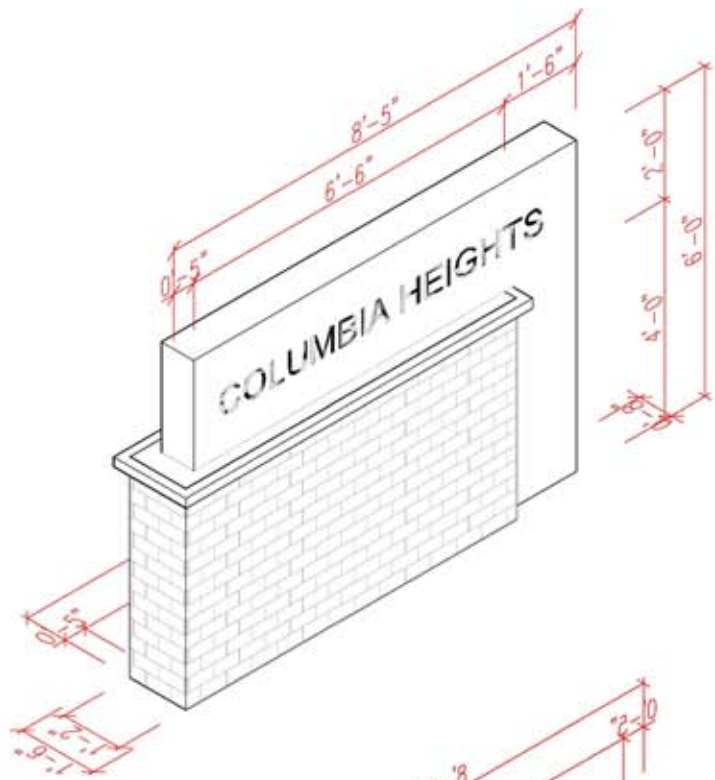

COLUMBIA HEIGHTS



## **CONDITIONS**

Z-22-1245596

R-75 (Residential Medium Lot-75) to R-60 (Residential Small Lot-60)

1. The development shall have a maximum of eleven single-family homes.
2. The main driveway shall be redesigned and to force vehicular movements in a right-turn in, right-turn out manner. Striping and signs shall be provided to direct drivers accordingly.

The approval of this rezoning application by the Board of Commissioners has no bearing on other approvals by the Zoning Board of Appeals or other authority, whose decision should be based on the merits of the application before said authority.

SITE DATA:  
EXISTING ZONING  
R-75



N/F PROPERTY OF  
 DEED BOOK 21733 / PAGE 441  
 DEED BOOK 23793 / PAGE 781

TRACT ONE 2.575 Acres 112,172 sq ft	TRACT TWO 0.220 Acres 9,578 sq ft
TOTAL SITE AREA 2.795 Acres 121,750 sq ft	

BOUNDARY & TOPOGRAPHIC SURVEY OF			
1484 Columbia Drive			
CS J B N :	20217054	DRAWING'S A/E:	1" = 30'
FIELD W R/R:	CS	DATE:	07-27-2021
PR J MGR:	JTN	UNINCORPORATED	REVISIONS (SEE GENERAL NOTES)
REVIEWED:	DLH	UNTY: DEKALB	STATE: GA
DWG FILE: 20217054-01.dwg	DISTR I: 15TH	LAND L T: 186	